

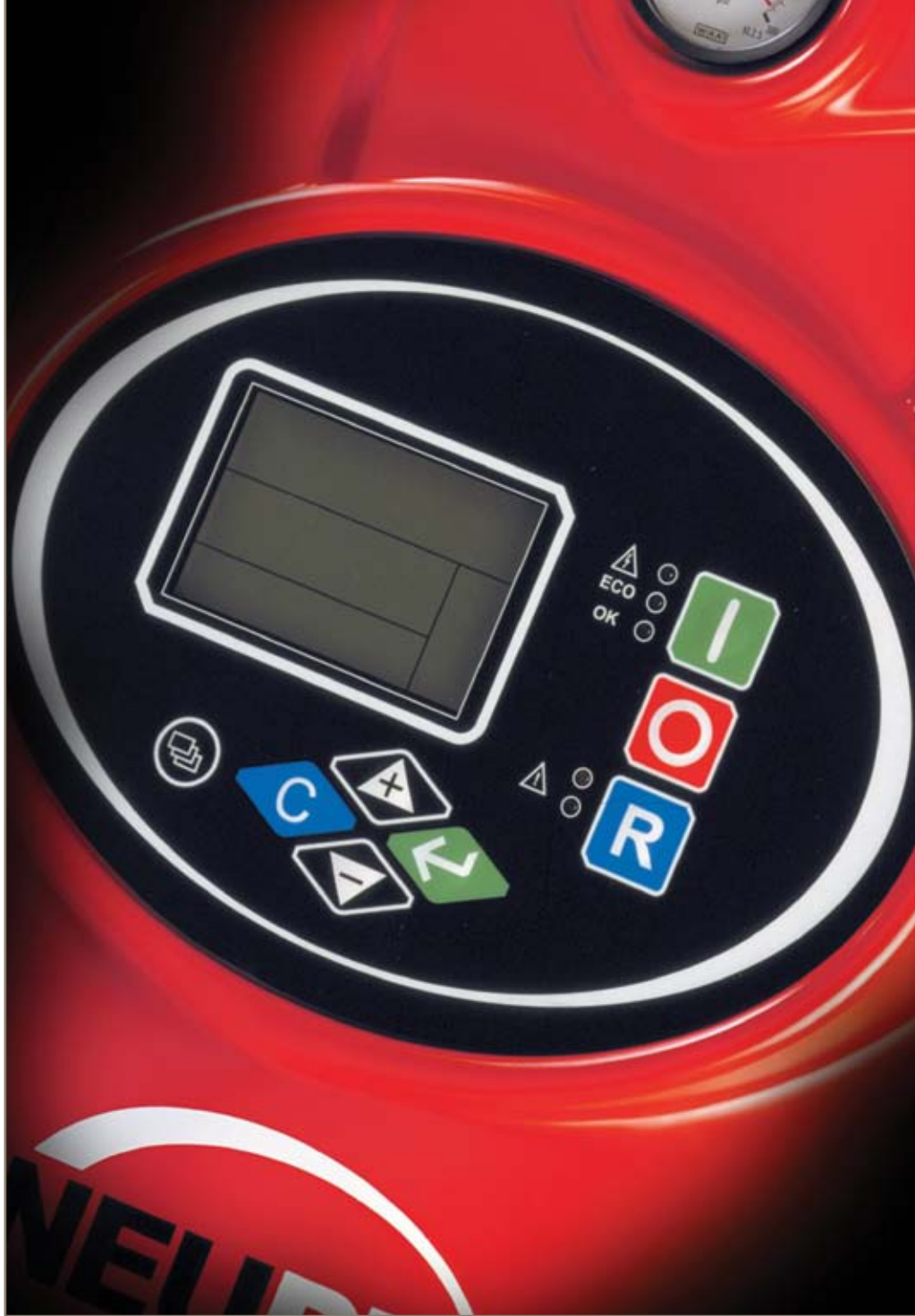

aerospace
climate control
electromechanical
filtration
fluid & gas handling
hydraulics
pneumatics
process control
sealing & shielding



PNEUDRI

Compressed Air Desiccant Dryers

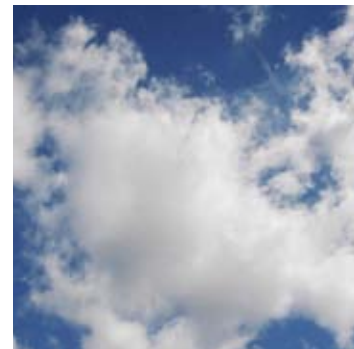

ENGINEERING YOUR SUCCESS.

Moisture is a big problem for compressed air users

Moisture is one of the major contaminants in compressed air systems. It occurs because water vapour present in the atmosphere is drawn into the compressor, where its' concentration can rise dramatically as temperature increases. Of the ten contaminants commonly found in a compressed air system, water vapour, liquid water and aerosols account for the majority of problems experienced by the compressed air user.



Unseen water vapour condenses into liquid water

Large volumes of atmospheric air enter the compressed air system through the compressor intake. As the air is compressed, its temperature increases significantly, causing it to become fully saturated with water vapour. Water vapour retention in air is dependent upon its temperature and pressure; the higher the temperature, the more water vapour that can be retained; the higher the pressure, the greater the amount of condensed water that will be released.

After the compression stage, the now saturated air is cooled to a usable temperature by an aftercooler, causing the retained water vapour to be condensed

into liquid water which is then removed by a condensate drain. The air leaving the aftercooler is now 100% saturated with water vapour. As the compressed air moves downstream to storage vessels and through piping, its temperature falls and concentrated vapour will sublimate as droplets of liquid water.

If not removed, this will cause corrosion of the distribution system, blocked or frozen valves and machinery, as well as providing an ideal breeding ground for micro-organisms and bacteria.

To eliminate these moisture problems, all viable water vapour must be removed by adsorption dryers, before it can enter the compressed air system.



How much water can be found in a typical compressed air system?

The amount of water in a compressed air system is staggering. A small 2.8m³/min (100 cfm) compressor and refrigeration dryer combination, operating for 4000 hours in typical Northern European climatic conditions can produce approximately 10,000 litres or 2,200 gallons of liquid condensate per year.

Oil is often perceived to be the most prolific contaminant as it can be seen emanating from open drain points and exhausting valves. In the majority of instances, it is

actually oily condensate (oil mixed with water) that is being observed. In reality, oil accounts for less than 0.1% of the overall volume.

This example illustrates the use of a small compressor to highlight the large volume of condensate produced. Up to 99.9% of the total liquid contamination found in a compressed air system is water.

If a compressed air system was operated in warmer, more humid climates, with larger compressors, or run for longer periods, the volume of condensate would increase significantly.

99.9% of the total liquid contamination in a compressed air system is water.

PNEUDRI modular compressed air dryers - a dedicated solution for every application

By combining the proven benefits of desiccant drying with modern design, Parker domnick hunter has produced an extremely compact and reliable system to totally dry and clean compressed air.



PNEUDRI MIDAS
Flowrates from
5.1m³/hr >



PNEUDRI MIDiplus
Flowrates from
49m³/hr >



PNEUDRI DH MAXI
Flowrates from
238m³/hr >



PNEUDRI MPX
Flowrates from
2346m³/hr >



PNEUDRI MX
Flowrates from
408m³/hr >

The Parker domnick hunter PNEUDRI ranges of heatless and heat regenerative dryers have proven to be the ideal solution for many thousands of compressed air users worldwide in a wide variety of industries.

Compressed air purification equipment must deliver uncompromising performance and reliability whilst providing the right balance of air quality with the lowest cost of operation.

Benefits:

Highest quality air

- Clean, oil-free and dry compressed air in accordance with all editions of ISO8573-1, the international standard for compressed air quality

Energy efficient

- Giving maximum savings

Dry air eliminates microbiological growth

- Preventing product spoilage, recall and litigation

Dry air means zero corrosion

- Preventing product spoilage and damage

Smaller, more compact and lightweight

- Modular construction means less than half the size of conventional dryers

Modular design

- 100% standby at a fraction of the cost of twin tower designs
- 10 year guarantee on pressure envelope
- Corrosion resistance due to alochroming and epoxy painting
- Constant dewpoint performance thanks to snowstorm filling

Approvals to international standards

- PED, CE, CSA (US+Canada), CRN

Easy and flexible installation

- Minimal space required

Simple maintenance

- Giving reduced downtime

Reduced noise pollution

- Super quiet operation

Clean, dry air improves production efficiency and reduces maintenance costs and downtime. Only an adsorption dryer can provide the highest levels of dry compressed air.

PNEUDRI - How it works

PNEUDRI comprises of high tensile extruded aluminium columns each containing twin chambers filled with desiccant material which dries the compressed air as it passes through.

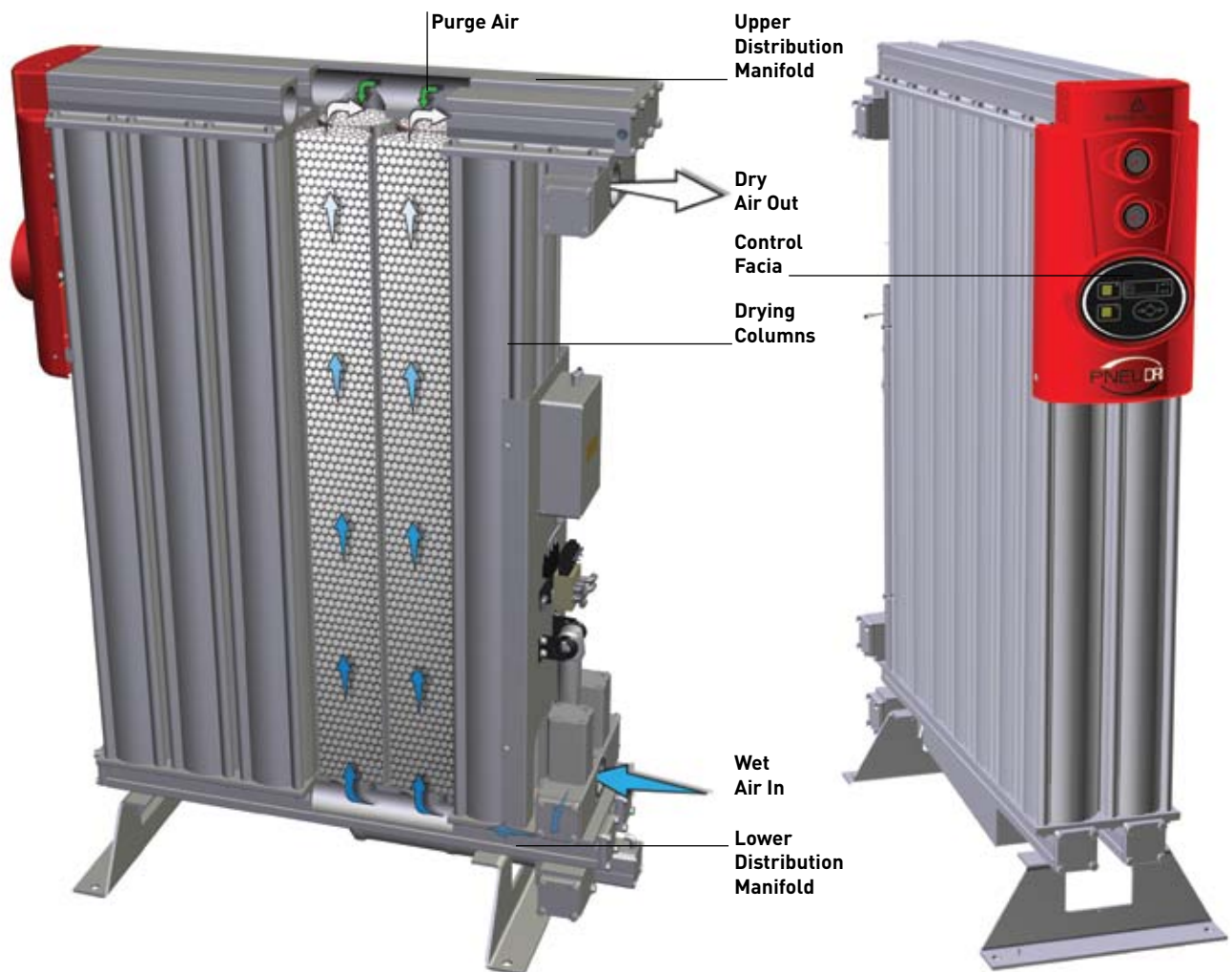

One chamber is operational (drying), while the opposite chamber is regenerating using either the Pressure Swing Adsorption (PSA) (heatless) or Thermal Swing Adsorption (TSA) (heat regenerative) method of drying.

A small volume of the dried compressed air is used to regenerate the saturated desiccant bed by expanding air from line pressure to atmospheric pressure, removing the water vapour adsorbed by the desiccant material,

and therefore regenerating the dryer. Heat regenerative models have electric heaters built into the desiccant beds to further reduce purge air consumption and increase operating efficiency.

Modular design eliminates the need for complex valves and interconnecting piping which are used in conventional twin tower designs.

PNEUDRI - The world's most advanced modular drying system

With the proven benefit of advanced aluminium forming technology, Parker domnick hunter has developed a twin tower desiccant dryer that is typically 60% of the size and weight of conventional designs.

These advanced desiccant dryers include ranges of heatless and heat-regenerative PNEUDRI dryers which provide one of the most simple and cost effective compressed air drying solutions. Engineers at Parker domnick hunter have developed PNEUDRI using innovative aluminium forming technology, resulting in units that are typically 60% of the size and weight of conventional welded steel desiccant air dryers. Using a single, high tensile extruded aluminium column, the PNEUDRI modular design

eliminates the need for complex valves or interconnecting piping.

Also, the length to diameter ratio of the internal voids and non-welded construction means that PNEUDRI does not require periodic inspections for insurance purposes, unlike traditional twin-tower air dryers that require out of service periods which can severely disrupt production schedules.



Drying Columns



Distribution Manifold

Greater flexibility with multi-banking



Multi-banking

Unlike traditional twin tower dryer designs, PNEUDRI MAXI models can be multi-banked to provide extra compressed air drying capacity should demand increase in the future. There is no need to replace the dryer with a larger unit, additional capacity can be covered by simply adding extra bank(s), a feature only available with PNEUDRI.



Flexibility during maintenance

Multi-banking allows individual dryer banks to be easily isolated for routine service work, whilst maintaining your clean, dry air supply.

100% stand-by

Compared to traditional twin tower designs, 100% standby is available at a fraction of the cost as only one extra dryer bank is required.

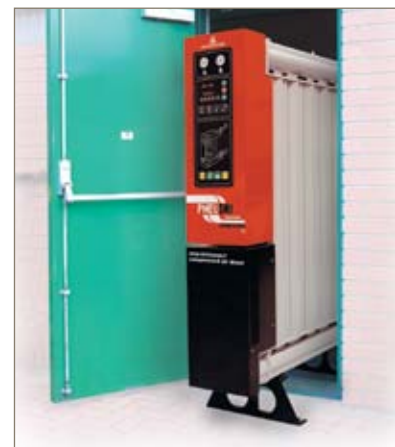

Fits through a standard doorway

Unlike traditional twin tower designs, PNEUDRI dryers will fit through a standard doorway, eliminating the need for special access or facility structural dismantling during installation.

PNEUDRI - four key features guarantee air quality

OIL-X EVOLUTION filtration

Adsorption dryers are designed for the removal of water vapour and not liquid water, water aerosols, oil, particulates or micro-organisms. Only by using Parker domnick hunter OIL-X EVOLUTION pre and after filtration can the removal of these contaminants be assured and air quality in accordance with all editions of ISO8573-1 be guaranteed.



Modular aluminium design

Aluminium extrusions are used throughout for drying chambers and distribution manifolds. This design allows the desiccant material to be retained within the drying chambers. 'Snowstorm' filling, prevents movement of the desiccant material during operation and also eliminates desiccant attrition and breakdown which could lead to a loss of pressure dewpoint.

Adsorbent desiccant material

Specially selected desiccant materials provide:

- Optimum adsorption and regeneration capacity - to ensure consistent dewpoint
- Low dusting - to prevent blockage of downstream filtration
- High crush strength - to prevent breakdown of the desiccant during operation
- High resistance to aggressive and oil-free condensate - for compatibility with all types of air compressor, their lubricants and condensate



'Snowstorm' filling ensures consistent dewpoint performance

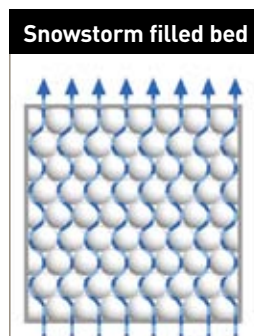

Consistent drying with no desiccant attrition

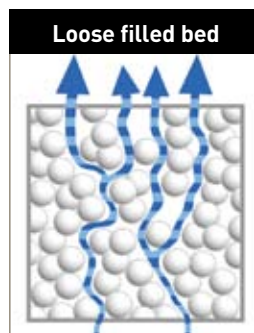

Inconsistent drying and desiccant attrition

'Snowstorm' filling method

Unique to Parker domnick hunter modular dryers is the snowstorm filling technique used to charge the drying chambers with adsorbent desiccant material.

The benefits are:

- Achieves maximum packing density for the desiccant material, fully utilising all of the available space envelope
- Prevents air channelling through the desiccant as experienced with twin tower designs. Due to channelling, twin tower designs require more desiccant to achieve an identical dewpoint, increasing physical size, operational and maintenance costs
- Prevents desiccant attrition which can lead to dusting, blocked filters and loss of dewpoint
- Allows 100% of the available desiccant material to be used for drying, therefore reducing the amount of desiccant required and maintenance costs
- 100% of the desiccant is regenerated ensuring consistent dewpoint
- Provides a low, equal resistance to air flow allowing multiple drying chambers and multiple dryer banks to be used, a feature only available with PNEUDRI

What air quality do I need?

The compressed air PDP should not only be selected to prevent condensation and freezing in the piping, consideration must also be given to the requirements of the application.

Typically, refrigeration dryers are employed for general purpose plant air. However, a significant amount of water vapour still remains in the compressed air, much more than is tolerable for most applications (air after an adsorption dryer with -40°C Pressure Dew Point (PDP) is around 60 times dryer than air after a refrigeration dryer with a $+3^{\circ}\text{C}$ PDP). Many critical applications require a PDP well below those offered by refrigeration

dryers, for example, compressed air with a PDP better than -26°C will inhibit growth of micro-organisms, which is well beyond the capabilities of a refrigeration dryer. Preventing the growth of these microbiological contaminants is crucial to industries such as food, beverage, pharmaceutical, medical, dental, electronics, cosmetics and any application where compressed air is used to provide breathable air.

The quality of air required throughout a typical compressed air system will vary depending upon the application for which it is used.



Critical Applications

Pharmaceutical products
Silicon wafer manufacturing
TFT / LCD screen manufacturing
Memory device manufacturing
Optical storage devices (CD, CD/RW, DVD, DVD/RW)
Optical disk manufacturing (CD's/DVD's)
Hard disk manufacturing
Foodstuffs
Dairies
Breweries
CDA systems for electronics manufacturing

For ultra-critical applications which require the driest possible air, -70°C PDP must be specified.



High Quality Oil-Free Air

Blow moulding of plastics e.g. P.E.T. bottles
Film processing
Critical instrumentation
Advanced pneumatics
Air blast circuit breakers
Decompression chambers
Cosmetic production
Medical air
Dental air
Robotics
Spray painting
Air bearings
Measuring equipment
Pre-treatment for on-site gas generation



General Purpose Oil-Free Air

General ring main protection
Plant automation
Air logistics
Pneumatic tools
General instrumentation
Metal stamping
Forging
General manufacturing (no external piping)
Air conveying
Air motors
Workshop (tools)
Temperature control systems
Blow guns
Gauging equipment
Raw material mixing
Sand / bead blasting
Yard air

Selecting the right dryer for your compressed air system

To achieve the degree of air quality specified by ISO8573-1:2010, a careful approach to system design, commissioning and operation must be adopted.

Parker domnick hunter recommends that compressed air is treated:

- Prior to entry into the distribution system
- At critical usage points and applications

This ensures that contamination already in the distribution system is removed.

Purification equipment should be installed where the air is at the lowest possible temperature (i.e. downstream of after-coolers and air receivers). Point-of-use purification equipment should be installed as close as possible to the application.

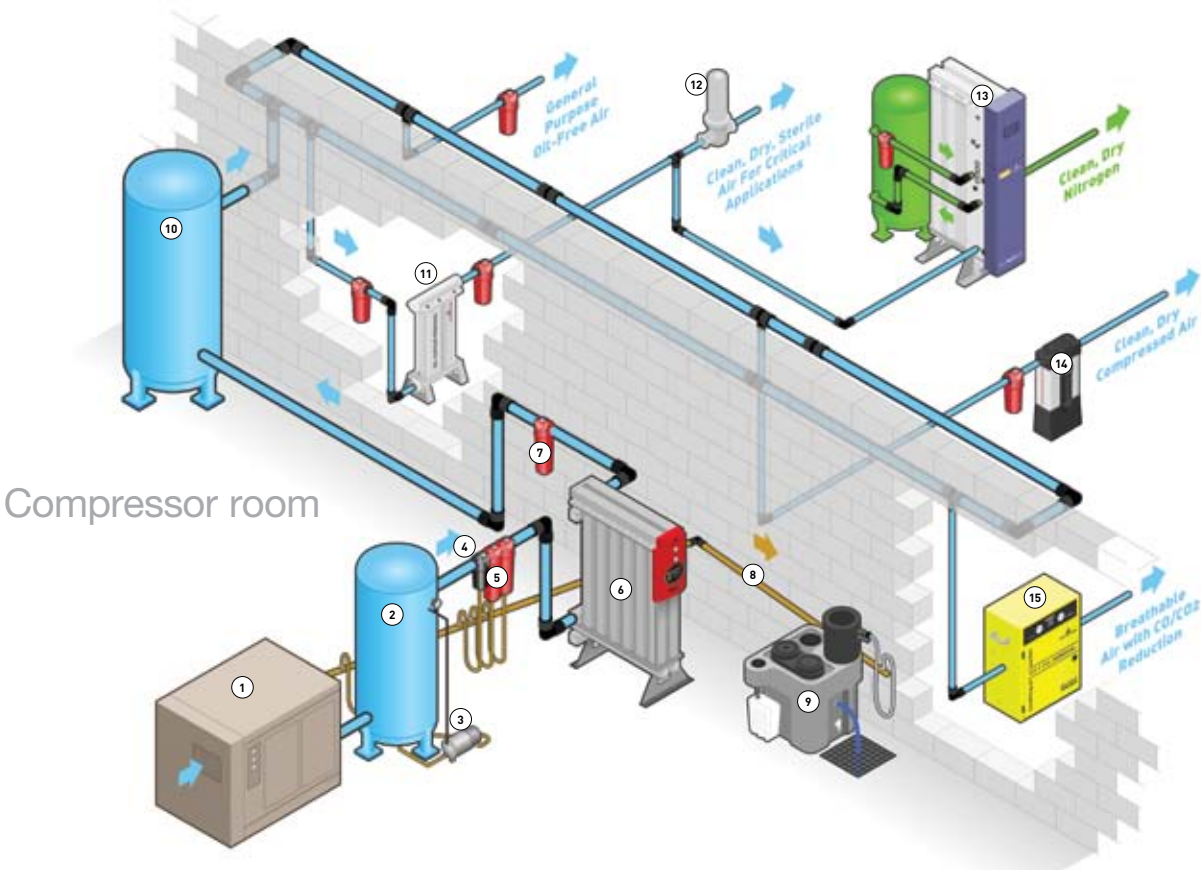

Key

1	Air Compressor	6	Modular Adsorption Dryer	11	Oil Vapour Removal
2	Wet Air Receiver	7	Dust Filter	12	Sterile Air Filter
3	Condensate Drain	8	Condensate Drainage	13	On-site Nitrogen Gas Generator
4	Water Separator	9	Oil / Water Separator	14	Point of use Adsorption Dryer
5	Coalescing Filters	10	Dry Air Receiver	15	Breathing Air Purifier

What size PNEUDRI do I require?

Dryer Selection

To correctly select a dryer model, the flow rate of the dryer must be adjusted for the minimum operating pressure and maximum operational temperature of the system. If the dewpoint required is different to the standard dewpoint of the dryer then the flow rate must also be adjusted for the required outlet dewpoint.

Selection Example

Selecting a dryer for a compressor producing at full load 1500 m³/hr at 8.3 bar g with 38°C air inlet temperature and a pressure dewpoint of -40°C.

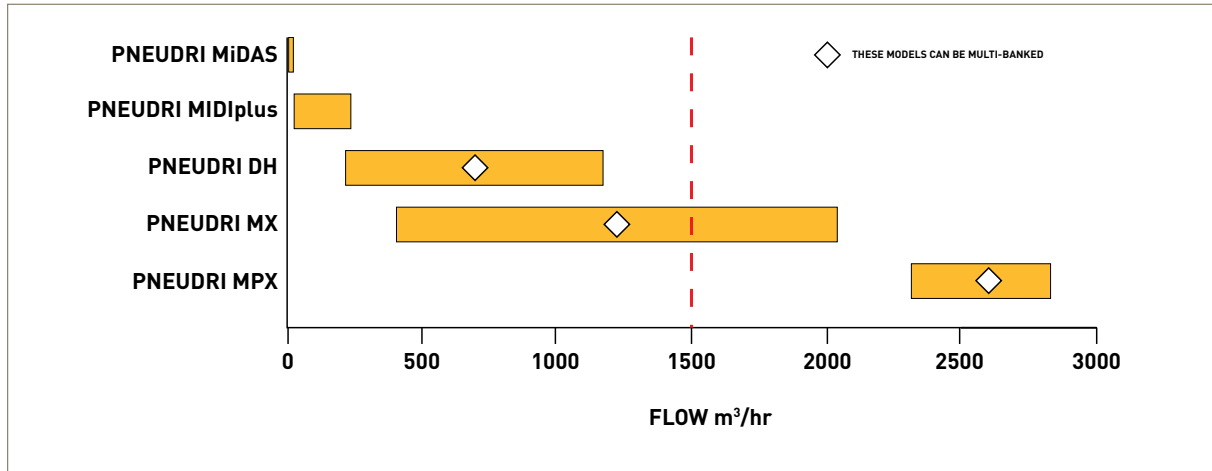

Step 1

Select the correction factor for maximum inlet temperature from the CFT table Correction Factor for 38°C (round up to 40°C) = 1.04

Temperature Correction Factor CFT		
Maximum Inlet Temperature	°C	40
	°F	104
	CFT	1.04

Step 2

Select the correction factor for minimum operating pressure from the CFP table Correction Factor for 8.3 bar g (round down to 8 bar g) = 0.89

Pressure Correction Factor CFP		
Minimum Inlet Pressure	bar g	8
	psi g	116
	CFP	0.89

Step 3

Select the correction factor for the required dewpoint from the CFD table Correction Factor for -40°C PDP = 1.00

Dewpoint Correction Factor CFD		
Required Dewpoint	PDP °C	-40
	PDP °F	-40
	CFD	1.00

Step 4

Calculate the minimum drying capacity

Minimum drying capacity = Compressed air flow rate x CFT x CFP x CFD
 Minimum drying capacity = 1500 m³/hr x 1.04 x 0.89 x 1.00 = 1388 m³/hr
 Model selected = MX106

Step 5

Which controller is required?

SMART controller is required therefore model selected = MXS106

Step 6

Is DDS Energy Management System required?

DDS Energy Management system is required therefore model selected = MXS106DS

If the minimum drying capacity exceeds the maximum values of the models shown within the tables, please contact Parker domnick hunter for advice regarding larger multi-banked dryers.

PNEUDRI MiDAS

Product Selection

Model	Pipe Size	Inlet Flowrates			
		L/S	m ³ /min	m ³ /hr	cfm
DAS1	G 3/8	1	0.09	5.1	3
DAS2	G 3/8	2	0.14	8.5	5
DAS3	G 3/8	4	0.23	13.6	8
DAS4	G 3/8	5	0.28	17.0	10
DAS5	G 3/8	6	0.37	22.1	13
DAS6	G 3/8	7	0.43	25.5	15
DAS7	G 3/8	9	0.57	34.0	20



Stated flows are for operation at 7 bar g (100 psi g) with reference to 20°C, 1 bar a, 0% relative water vapour pressure. For flows at other pressures, apply the correction factors shown.

Dryer Performance

Dryer Models	*Dewpoint (Standard)		ISO8573-1:2010 Classification (standard)	*Dewpoint (Option 1)		ISO8573-1:2010 Classification (Option 1)
	°C	°F		°C	°F	
DAS	-40	-40	Class 2	-70	-100	Class 1

Technical Data

Dryer Models	Min Operating Pressure		Max Operating Pressure		Min Inlet Temperature		Max Inlet Temperature		Max Ambient Temperature	
	bar g	psi g	bar g	psi g	°C	°F	°C	°F	°C	°F
DAS	4	58	12	175	2	35	50	122	55	131

Dryer Models	Electrical Supply (Standard) Tolerance ± 10%	Electrical Supply (Optional) Tolerance ± 10%	Thread Connection	Noise Level (average)	Electronic Controller Options	Function	
				dB(A)		Power On Indication	Service Interval Indication
DAS	230 / 1ph / 50Hz	115 / 1ph / 60Hz	BSPP or NPT	<75	DAS	•	•

For fully pneumatic applications, a PNEUDRI MINI range is available. Please contact Parker domnick hunter for further information.

Correction Factors

Temperature Correction Factor CFT							
Maximum Inlet Temperature	°C	25	30	35	40	45	50
	°F	77	86	95	104	113	122
	CFT	1.00	1.00	1.00	1.04	1.14	1.37

Pressure Correction Factor CFP										
Minimum Inlet Pressure	bar g	4	5	6	7	8	9	10	11	12
	psi g	58	73	87	102	116	131	145	160	174
	CFP	1.60	1.33	1.14	1.00	1.03	0.93	0.85	0.78	0.71

Dewpoint Correction Factor CFD			
Required Dewpoint	Standard		Option 1
	PDP °C	-40	-70
	PDP °F	-40	-100
CFD	1.00	1.43	

Weights and Dimensions

Model	Pipe Size	Dimensions						Weight	
		Height (H)		Width (W)		Depth (D)		Kg	lbs
		mm	ins	mm	ins	mm	ins		
DAS1	G 3/8	422	16.6	289	11.4	149	5.9	11	24.2
DAS2	G 3/8	500	19.7	289	11.4	149	5.9	13	28.7
DAS3	G 3/8	616	24.2	289	11.4	149	5.9	16	35.3
DAS4	G 3/8	692	27.2	289	11.4	149	5.9	18	39.7
DAS5	G 3/8	847	33.3	289	11.4	149	5.9	20	44.1
DAS6	G 3/8	906	35.7	289	11.4	149	5.9	23	50.7
DAS7	G 3/8	1098	43.2	289	11.4	149	5.9	28	61.7

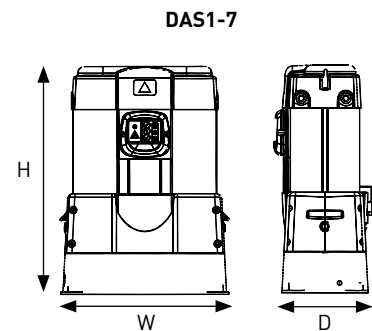

Recommended Filtration

Model	Filter Pipe Size BSPT or NPT	Inlet General Purpose Pre-filter	Inlet High Efficiency Filter	Outlet Dust Filter
DAS1	3/8"	AO005B □ FX	N/A*	N/A*
DAS2	3/8"	AO005B □ FX	N/A*	N/A*
DAS3	3/8"	AO005B □ FX	N/A*	N/A*
DAS4	3/8"	AO005B □ FX	N/A*	N/A*
DAS5	3/8"	AO005B □ FX	N/A*	N/A*
DAS6	3/8"	AO0010B □ FX	N/A*	N/A*
DAS7	3/8"	AO0010B □ FX	N/A*	N/A*

*MiDAS dryers include integral high efficiency pre and general purpose dust filters.

□ = B (BSPT) or N (NPT)

PNEUDRI MIDiplus

Product Selection

Model	Pipe Size	Inlet Flowrates			
		L/S	m ³ /min	m ³ /hr	cfm
DME012	G 3/4	11	0.68	41	24
DME015	G 3/4	15	0.91	55	32
DME020	G 3/4	20	1.19	71	42
DME025	G 3/4	25	1.50	90	53
DME030	G 3/4	31	1.84	110	65
DME040	G 3/4	42	2.49	149	88
DME050	G1	50	3.01	180	106
DME060	G1	61	3.69	221	130
DME080	G1	83	4.99	299	176



Stated flows are for operation at 7 bar g (100 psi g) with reference to 20°C, 1 bar a, 0% relative water vapour pressure. For flows at other pressures, apply the correction factors shown.

Dryer Performance

Dryer Models	Dewpoint (Standard)		ISO8573-1:2010 Classification (standard)	Dewpoint (Option 1)		ISO8573-1:2010 Classification (Option 1)
	°C	°F		°C	°F	
DME	-40	-40	Class 2	-70	-100	Class 1
DMP*	-40	-40	Class 2	-70	-100	Class 1

Technical Data

Dryer Models	Min Operating Pressure		Max Operating Pressure		Min Operating Temperature		Max Operating Temperature		Max Ambient Temperature		Electrical Supply (Standard)	Electrical Supply (Optional)	Thread Connection	Noise Level dB(A)
	bar g	psi g	bar g	psi g	°C	°F	°C	°F	°C	°F				
DME012 - DME040	4	58	16	232	2	35	50	122	55	131	230V 1ph 50/60Hz	110V 1ph 50/60Hz	BSPP or NPT	<75
DME050 - DME080	4	58	13	190	2	35	50	122	55	131	230V 1ph 50/60Hz	110V 1ph 50/60Hz	BSPP or NPT	<75
DMP12P - DMP80P*	4	58	10.5	152	2	35	50	122	55	131	FULLY PNEUMATIC		BSPP or NPT	<75

Controller Options

Controller Options	Function								
	Power On Indication	Fault Indication	Display Fault Condition Values	Service Interval Indication	Service Countdown Timers	Configurable Alarm Settings	Remote Volt Free Alarm contacts	Filter Service Timer	DDS Energy Management System
DME (Electronic control)	•	•					•		
DME DDS	•	•					•		•

***ATEX compliant option available.**

For hazardous environments, a fully pneumatic ATEX compliant version of PNEUDRI is available.

ATEX Directive 94/9/EC
Group II, Category 2GD, T6.

Correction Factors

Temperature Correction Factor CFT							
Maximum Inlet Temperature	°C	25	30	35	40	45	50
	°F	77	86	95	104	113	122
	CFT	1.00	1.00	1.00	1.04	1.14	1.37

Pressure Correction Factor CFP														
Minimum Inlet Pressure	bar g	4	5	6	7	8	9	10	11	12	13	14	15	16
	psi g	58	73	87	100	116	131	145	160	174	189	203	218	232
	CFP	1.60	1.33	1.14	1.00	0.89	0.80	0.73	0.67	0.62	0.57	0.54	0.5	0.47

Dewpoint Correction Factor CFD		Standard	Option 1
Required Dewpoint	PDP °C	-40	-70
	PDP °F	-40	-100
	CFD	1.00	1.43

Models 012 - 040 only

Weights and Dimensions

Model	Pipe Size Inlet / Outlet	Dimensions						Weight	
		Height (H)		Width (W)		Depth (D)		kg	lbs
		mm	ins	mm	ins	mm	ins		
DME012	G 3/4	837	33.0	284	11.2	302	11.9	32	70
DME015	G 3/4	1003	39.5	284	11.2	302	11.9	37	81
DME020	G 3/4	1168	46.0	284	11.2	302	11.9	42	92
DME025	G 3/4	1333	52.5	284	11.2	302	11.9	47	103
DME030	G 3/4	1499	59.0	284	11.2	302	11.9	52	114
DME040	G 3/4	1747	68.8	284	11.2	302	11.9	60	132
DME050	G 1	1433	56.4	220	8.7	566	22.3	80	176
DME060	G 1	1599	63.0	220	8.7	566	22.3	90	198
DME080	G 1	1847	72.7	220	8.7	566	22.3	104	229

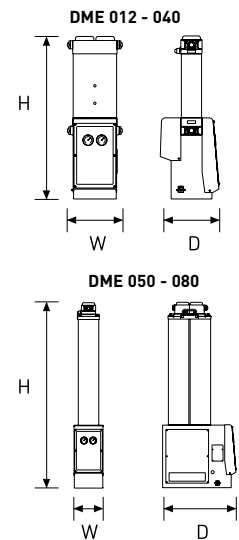

Recommended Filtration

For Dryer Model	Filter Pipe Size BSPT or NPT	Inlet General Purpose Pre-filter	Inlet High Efficiency Filter	Outlet Dust Filter
DME012	3/4"	AO020D □ FX	AA020D □ FX	AR020D □ MX
DME015	3/4"	AO020D □ FX	AA020D □ FX	AR020D □ MX
DME020	3/4"	AO020D □ FX	AA020D □ FX	AR020D □ MX
DME025	3/4"	AO020D □ FX	AA020D □ FX	AR020D □ MX
DME030	3/4"	AO020D □ FX	AA020D □ FX	AR020D □ MX
DME040	3/4"	AO025D □ FX	AA025D □ FX	AR025D □ MX
DME050	1"	AO025E □ FX	AA025E □ FX	AR025E □ MX
DME060	1"	AO030E □ FX	AA030E □ FX	AR030E □ MX
DME080	1"	AO030E □ FX	AA030E □ FX	AR030E □ MX

□ = B (BSPT) or N (NPT)

PNEUDRI DH

Product Selection

	Model	Pipe Size	Inlet Flowrates			
			L/S	m ³ /min	m ³ /hr	cfm
Single Bank	DH □ 102	G 2	66	3.97	238	140
	DH □ 104	G 2	132	7.95	476	280
	DH □ 106	G 2½	198	11.92	714	420
	DH □ 108	G 2½	264	15.88	951	560
	DH □ 110	G 2½	330	19.86	1189	700
Multi-Bank	2 x DH □ 108	G 2½	528	31.76	1902	1120
	2 x DH □ 110	G 2½	661	39.71	2378	1400
	3 x DH □ 108	G 2½	793	47.65	2853	1679
	3 x DH □ 110	G 2½	991	59.57	3567	2100
	4 x DH □ 108	G 2½	1057	63.53	3804	2239
	4 x DH □ 110	G 2½	1321	79.43	4756	2779



Stated flows are for operation at 7 bar g (100 psi g) with reference to 20°C, 1 bar a, 0% relative water vapour pressure. For flows at other pressures apply the correction factors shown.

Dryer Performance

Dryer Models	Dewpoint (Standard)		ISO8573-1:2010 Classification (standard)	Dewpoint (Option 1)		ISO8573-1:2010 Classification (Option 1)
	°C	°F		°C	°F	
DH □	-40	-40	Class 2	-70	-100	Class 1

Technical Data

Dryer Models	Min Operating Pressure		Max Operating Pressure		Min Inlet Temp		Max Inlet Temp		Max Ambient Temp		Electrical supply (standard)	Electrical supply (optional)	Thread Connections	Noise Level dB (A)
	bar g	psi g	bar g	psi g	°C	°F	°C	°F	°C	°F				
DH □	4	58	10.5	154	2	35	50	122	55	131	415V 3ph+N	N/A	BSPP or NPT	<75

Power Consumption

Model	Power Consumption	
	KW h Average	Full Load Amps
DH □ 102	1.3	7.2
DH □ 104	2.6	14.4
DH □ 106	4.0	21.6
DH □ 108	5.3	28.8
DH □ 110	6.6	36
2 x DH □ 108	10.6	57.6
2 x DH □ 110	13.2	72
3 x DH □ 108	15.9	86.4
3 x DH □ 110	19.8	108
4 x DH □ 108	21.2	115.2
4 x DH □ 110	26.4	144

Heat Regenerative models have electric heaters built into the desiccant beds to further reduce purge air consumption and increase operating efficiency.

Controller Options

Controller Options	Function									
	Power on Indication	Fault Indication	Display Fault Condition Values	Service Interval Indication	Service Countdown Timers	Configurable Alarm Settings	Remote Volt Free Alarm Contacts	Filter Service Timer	DDS Energy Management System	
SMART	•	•					•			
SMART DDS	•	•					•		•	
Electronic DDS	•	•	•	•	•	•	•	•	•	

Correction Factors

Temperature Correction Factor CFT							
Maximum Inlet Temperature	°C	25	30	35	40	45	50
	°F	77	86	95	104	113	122
	CFT	0.91	1.00	1.00	1.32	1.73	2.23

Pressure Correction Factor CFP									
Minimum Inlet Pressure	bar g	4	5	6	7	8	9	10	10.5
	psi g	58	73	87	102	116	131	145	152
	CFP	1.60	1.33	1.14	1.00	0.89	0.80	0.73	0.70

Dewpoint Correction Factor CFD		Standard	Option 1
Required Dewpoint	PDP °C	-40	-70
	PDP °F	-40	-100
	CFD	1.00	1.43

Weights and Dimensions

Model	Pipe Size	Dimensions						Weight	
		Height (H)		Width (W)		Depth (D)		kg	lbs
		mm	ins	mm	ins	mm	ins		
DH □ 102	G 2	1578	62.1	717	28.2	321	12.6	150	331
DH □ 104	G 2	1578	62.1	947	37.3	321	12.6	245	540
DH □ 106	G 2½	1578	62.1	1177	46.3	321	12.6	325	717
DH □ 108	G 2½	1578	62.1	1407	55.4	321	12.6	440	970
DH □ 110	G 2½	1578	62.1	1637	64.4	321	12.6	565	1246

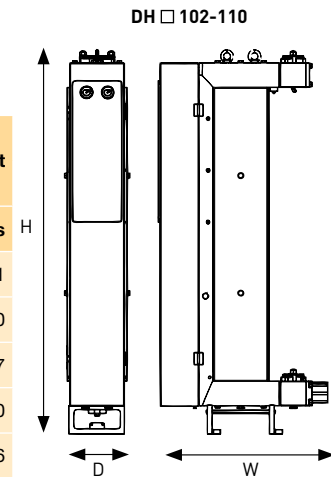

Recommended Filtration

Model	Filter Pipe Size BSPT or NPT	Inlet General Purpose Pre-filter	Inlet High Efficiency Filter	Outlet Dust Filter
DH □ 102	2"	AO040H □ FX	AAO40H □ FX	ARO40H □ MX
DH □ 104	2"	AO040H □ FX	AAO40H □ FX	ARO40H □ MX
DH □ 106	2 ½"	AO050I □ FX	AAO50I □ FX	ARO50I □ MX
DH □ 108	2 ½"	AO050I □ FX	AAO50I □ FX	ARO50I □ MX
DH □ 110	2 ½"	AO050I □ FX	AAO50I □ FX	ARO50I □ MX

□ = B (BSPT) or N (NPT)

Dryer Coding Example

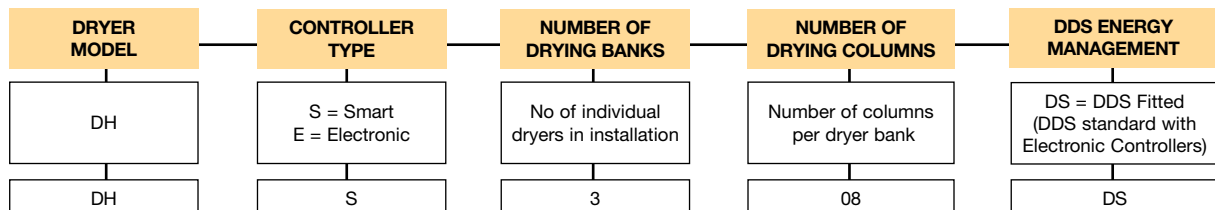

Example: PNEUDRI model DHS308DS

PNEUDRI MX

Product Selection

	Model	Pipe Size	Flowrates			
			L/s	m ³ /min	m ³ /hr	cfm
Single Bank	MX □ 102C	G 2	113	6.81	408	240
	MX □ 103C	G 2	170	10.22	612	360
	MX □ 103	G 2	213	12.78	765	450
	MX □ 104	G 2	283	17.03	1020	600
	MX □ 105	G 2½	354	21	1275	750
	MX □ 106	G 2½	425	26	1530	900
	MX □ 107	G 2½	496	30	1785	1050
	MX □ 108	G 2½	567	34	2040	1200
Multi-Bank	2 x MX □ 105	G 2½	708	43	2550	1500
	2 x MX □ 106	G 2½	850	51	3060	1800
	2 x MX □ 107	G 2½	992	60	3570	2100
	2 x MX □ 108	G 2½	1133	68	4080	2400
	3 x MX □ 106	G 2½	1275	77	4590	2700
	3 x MX □ 107	G 2½	1488	89	5355	3150
	3 x MX □ 108	G 2½	1700	102	6120	3600



Stated flows are for operation at 7 bar g (100 psi g) with reference to 20°C, 1 bar a, 0% relative water vapour pressure. For flows at other pressures apply the correction factors shown.

Dryer Performance

Dryer Models	Dewpoint (Standard)		ISO8573-1:2010 Classification (standard)	Dewpoint (Option 1)		ISO8573-1:2010 Classification (Option 1)	Dewpoint (Option 2)		ISO8573-1:2010 Classification (Option 2)
	°C	°F		°C	°F		°C	°F	
MX □	-40	-40	Class 2	-70	-100	Class 1	-20	-4	Class 3
MXP*	-40	-40	Class 2	-70	-100	Class 1	-20	-4	Class 3

Technical Data

Dryer Models	Min Operating Pressure		Max Operating Pressure		Min Operating Temp		Max Operating Temp		Max Ambient Temp		Electrical supply (standard)	Electrical supply (optional)	Thread Connections	Noise Level dB (A)
	bar g	psi g	bar g	psi g	°C	°F	°C	°F	°C	°F				
MXS	4	58	13	190	2	35	50	122	55	131	85 - 265 V 1ph 50/60Hz	N/A	BSPP or NPT	<75
MXA	4	58	13	190	2	35	50	122	55	131	85 - 265 V 1ph 50/60Hz	N/A	BSPP or NPT	<75
MXP*	4	58	13	190	2	35	50	122	55	131	N/A	N/A	BSPP or NPT	<75

Controller Options

Controller Options	Function								
	Power on Indication	Fault Indication	Display Fault Condition Values	Service Interval Indication	Service Countdown Timers	Configurable Alarm Settings	Remote Volt Free Alarm Contacts	Filter Service Timer	DDS Energy Management System
SMART	•	•		•			•		
SMART DDS	•	•		•			•		•
ADVANCED	•	•	•	•	•	•	•	•	•

***ATEX compliant option available.**

For hazardous environments, a fully pneumatic ATEX compliant version of PNEUDRI is available.

ATEX Directive 94/9/EC
Group II, Category 2GD, T6.

Correction Factors

Temperature Correction Factor CFT							
Maximum Inlet Temperature	°C	25	30	35	40	45	50
	°F	77	86	95	104	113	122
	CFT	1.00	1.00	1.00	1.04	1.14	1.37

Pressure Correction Factor CFP											
Minimum Inlet Pressure	bar g	4	5	6	7	8	9	10	11	12	13
	psi g	58	73	87	100	116	131	145	160	174	189
	CFP	1.60	1.33	1.14	1.00	0.89	0.80	0.73	0.67	0.62	0.57

Dewpoint Correction Factor CFD		Option 2	Standard	Option 1
Required Dewpoint	PDP °C	-20	-40	-70
	PDP °F	-4	-40	-100
	CFD	0.91	1.00	1.43

Weights and Dimensions

Model	Pipe Size	Dimensions						Weight	
		Height (H)		Width (W)		Depth (D)		kg	lbs
		mm	ins	mm	ins	mm	ins		
MX □ 102C	G 2	1647	64.8	687	27.0	550	21.7	235	518
MX □ 103C	G 2	1647	64.8	856	33.7	550	21.7	316	696
MX □ 103	G 2	1892	74.5	856	33.7	550	21.7	355	782
MX □ 104	G 2	1892	74.5	1025	40.3	550	21.7	450	992
MX □ 105	G 2½	1892	74.5	1194	47.0	550	21.7	543	1197
MX □ 106	G 2½	1892	74.5	1363	53.6	550	21.7	637	1404
MX □ 107	G 2½	1892	74.5	1532	60.3	550	21.7	731	1611
MX □ 108	G 2½	1892	74.5	1701	67.0	550	21.7	825	1818

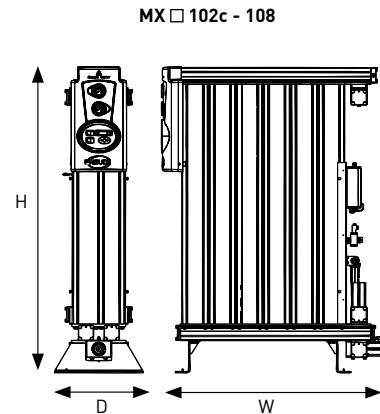

Recommended Filtration

For Dryer Model	Filter Pipe Size BSPT or NPT	Inlet General Purpose Pre-filter	Inlet High Efficiency Filter	Outlet Dust Filter
MX □ 102C	2"	AO040H □ FX	AA040H □ FX	AR040H □ MX
MX □ 103C	2"	AO040H □ FX	AA040H □ FX	AR040H □ MX
MX □ 103	2"	AO045H □ FX	AA045H □ FX	AR045H □ MX
MX □ 104	2"	AO045H □ FX	AA045H □ FX	AR045H □ MX
MX □ 105	2½"	AO050I □ FX	AA050I □ FX	AR050I □ MX
MX □ 106	2½"	AO055I □ FX	AA055I □ FX	AR055I □ MX
MX □ 107	2½"	AO055I □ FX	AA055I □ FX	AR055I □ MX
MX □ 108	2½"	AO055I □ FX	AA055I □ FX	AR055I □ MX

□ = B (BSPT) or N (NPT)

Dryer Coding Example

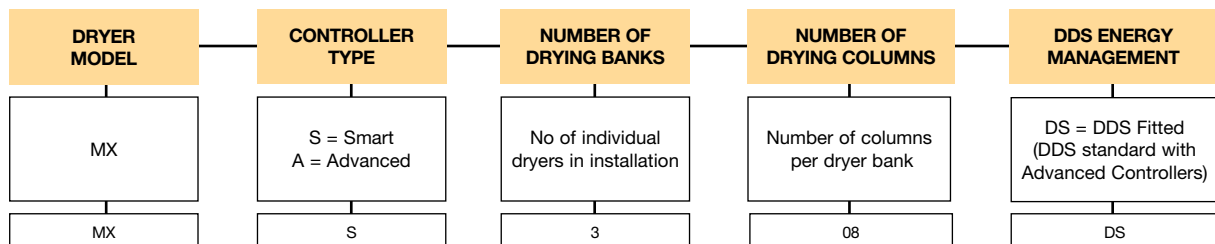

Example: PNEUDRI model MXS308DS

PNEUDRI MPX

Product Selection

Model	Pipe Size	Flowrates			
		L/s	m ³ /min	m ³ /hr	cfm
MPX □ 110	G 4	652	39	2346	1381
MPX □ 112	G 4	782	47	2815	1657
2 x MPX □ 110	G 4	1303	78	4692	2762
2 x MPX □ 112	G 4	1564	94	5630	3314
3 x MPX □ 110	G 4	1955	118	7038	4143
3 x MPX □ 112	G 4	2346	141	8445	4971



Stated flows are for operation at 7 bar g (100 psi g) with reference to 20°C, 1 bar a, 0% relative water vapour pressure. For flows at other pressures apply the correction factors shown.

Dryer Performance

Dryer Models	Dewpoint (Standard)		ISO8573-1:2010 Classification (standard)	Dewpoint (Option 1)		ISO8573-1:2010 Classification (Option 1)
	°C	°F		°C	°F	
MPX □	-40	-40	Class 2	-70	-100	Class 1

Technical Data

Dryer Models	Min Operating Pressure		Max Operating Pressure		Min Operating Temp		Max Operating Temp		Max Ambient Temp		Electrical supply (standard)	Electrical supply (optional)	Thread Connections	Noise Level dB (A)
	bar g	psi g	bar g	psi g	°C	°F	°C	°F	°C	°F				
MPX □	4	58	13	190	2	35	50	122	55	131	230 V 1ph 50/60Hz	110 V 1PH 50/60Hz	BSPP or NPT	<75

Controller Options

Controller Options	Function									
	Power on Indication	Fault Indication	Display Fault Condition Values	Service Interval Indication	Service Countdown Timers	Configurable Alarm Settings	Remote Volt Free Alarm Contacts	Filter Service Timer	DDS Energy Management System	
SMART	•	•		•			•			
SMART DDS	•	•		•			•		•	
ELECTRONIC DDS	•	•	•	•	•	•	•	•	•	•

Correction Factors

Temperature Correction Factor CFT							
Maximum Inlet Temperature	°C	25	30	35	40	45	50
	°F	77	86	95	104	113	122
	CFT	1.00	1.00	1.00	1.04	1.14	1.37

Pressure Correction Factor CFP											
Minimum Inlet Pressure	bar g	4	5	6	7	8	9	10	11	12	13
	psi g	58	73	87	100	116	131	145	160	174	189
	CFP	1.60	1.33	1.14	1.00	0.89	0.80	0.73	0.67	0.62	0.57

Dewpoint Correction Factor CFD			
Required Dewpoint	Standard		Option 1
	PDP °C	-40	-70
	PDP °F	-40	-100
CFD	1.00	1.43	

Weights and Dimensions

Model	Pipe Size	Dimensions						Weight	
		Height (H)		Width (W)		Depth (D)		kg	lbs
		mm	ins	mm	ins	mm	ins		
MPX □ 110	G 4	1788	70.4	2223	87.5	550	21.7	895	1969
MPX □ 112	G 4	1788	70.4	2551	100.4	550	21.7	1025	2255

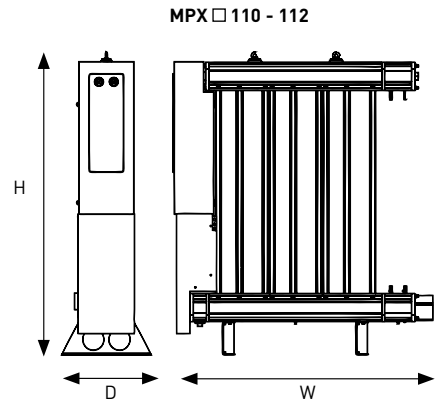

Recommended Filtration

Model	Filter Pipe Size BSPT or NPT	Inlet General Purpose Pre-filter	Inlet High Efficiency Filter	Outlet Dust Filter
MPX 110	4"	AO060K □ FX	AA060K □ FX	AR060K □ MX
MPX 112	4"	AO060K □ FX	AA060K □ FX	AR060K □ MX

□ = B (BSPT) or N (NPT)

Dryer Coding Example

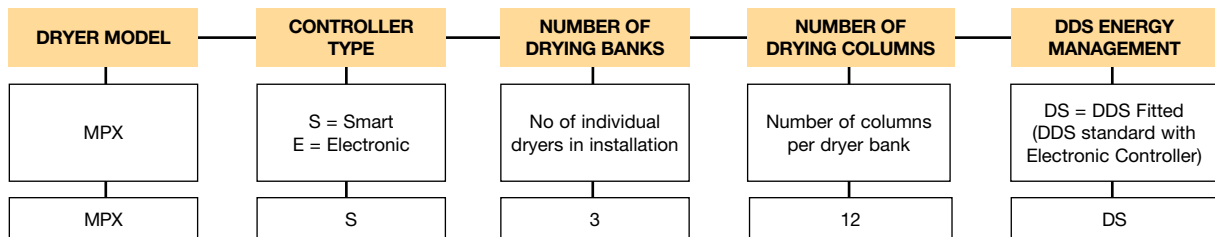

Example: PNEUDRI model MPXS312DS

The Parker domnick hunter design philosophy



Parker domnick hunter has been supplying industry with high efficiency filtration and purification products since 1963. Our philosophy 'Designed for Air Quality & Energy

Efficiency' ensures products that not only provide the user with clean, high quality compressed air, but also with low lifetime costs and reduced carbon dioxide (CO₂) emissions.

PNEUDRI Options

DDS Energy Management Systems

Operational costs associated with providing such dry compressed air can be high. If adsorption dryers are not optimised correctly, desiccant regeneration can consume huge amounts of energy; indeed, drying costs can often be as high as 80% of total operational costs.

To address this issue, Parker domnick hunter has developed a new generation of energy efficient air dryers that allows businesses to cut operating costs and remain environmentally responsible whilst providing the highest quality compressed air. PNEUDRI desiccant air dryers can be fitted with Dewpoint Dependent Switching (DDS) energy saving controls that eliminate unnecessary

desiccant regeneration cycles to provide considerable energy savings.

By directly monitoring the outlet air quality (dewpoint) of the dryer, the system can automatically extend the "drying period" beyond a normally fixed cycle time if the on-line drying chamber has adsorptive capacity remaining.

As compressed air systems rarely operate at full rated capacity all of the time (eg during shift work and periods of low demand), this energy management system can provide considerable savings.

During this extended period of energy free drying, no purge air energy is consumed for regeneration.

DDS Energy Saving (Heatless Dryer example shown)

Air Demand %	Energy Saving %	Energy Saving P/A Kw	Environmental Saving P/A Kg CO ₂
100	33.00	95,040	50,371
90	40.00	115,200	61,056
80	47.00	135,360	71,741
70	53.00	152,640	80,899
60	60.00	172,800	91,584
50	66.00	190,080	100,742

System pressure 6 bar g. Max Temp 35°C. System flow 1700 m³/hr (1000 cfm). Average pressure 6.5 bar g. Average Temp 30°C.



PNEUDRI for hazardous environments

Where clean, dry compressed air is required in hazardous environments, e.g. petrochemical and offshore oil & gas applications, Parker domnick hunter can supply fully pneumatic ATEX compliant PNEUDRI dryers.



**ATEX Directive 94/9/EC
Group II, Category 2GD, T6**



Flow Control Devices for multi-banked dryers

To prevent overflowing your compressed air system and to assist in maintaining pressure dewpoint, Flow Control Devices (FCD's) are available for multi-banked PNEUDRI DH, PNEUDRI MX and PNEUDRI MPX models.

For a set flowrate, air will flow through a uniform pipe at a constant velocity, however, the velocity will increase if there is a reduction in the pipe diameter.

If the pipe diameter is further decreased, the air flow will continue to increase to a maximum velocity.

FCD's or sonic nozzles will restrict the airflow to 125% of the dryers rated flow and any further attempt to increase the airflow will cause "choking" and a very high pressure drop.

Please contact Parker domnick hunter for further information.

Benefits

- Prevents significant overflow of the dryer.
- Helps to maintain a constant outlet pressure dewpoint.
- Indicates by high pressure drop when system demand exceeds rated capacity.



Aftermarket

Compressed air equipment users demand much more than the supply of high quality products in order to maintain a competitive edge.

Modern production technology is increasingly demanding the provision of a higher purity and more reliable compressed air supply. Products and solutions that are manufactured by Parker domnick hunter are designed to provide air quality that meets with and often exceeds international standards.

As well as the requirement for air purity and reliability, there are additional factors to consider when choosing the right service provider for your compressed air and gas purification system. For example, knowledge of the many regulations regarding the management of industrial waste, energy efficiency improvement programs and consideration of any environmental impact. It is anticipated that future legislations will demand further in-depth technical and knowledge-based support from service providers.

Our commitment to industry does not stop with the supply of high quality products. We are also committed to ensuring that our equipment provides high performance by providing a trouble-free service from a bespoke maintenance and verification package - all tailored to your own specific requirements.

We offer a wide range of valuable services that will impact positively on your drive towards improved production efficiency and product quality with reduced production rejections and operational costs.

From initial selection to installation, commissioning, preventative maintenance and specialised services, Parker domnick hunter is redefining customer service.



Filter Elements and Consumable Parts	Maintenance, Repair and Overhaul	Customer Support	Specialised Services
<ul style="list-style-type: none"> Genuine Replacement filter elements Preventative Maintenance Kits Repair Kits Installation Kits Upgrade Kits 	<ul style="list-style-type: none"> Installation and Commissioning Maintenance and Repair Updates and Upgrades Service Contracts Parts Service Warranty 	<ul style="list-style-type: none"> Business Development Technical Support Group Training Technical Publications 	<ul style="list-style-type: none"> Air Quality Testing Dewpoint Measurement Leak Detection Particle Counting Micro-biological Testing

Parker's Motion & Control Technologies

Parker is guided by a relentless drive to help our customers become more productive and achieve higher levels of profitability by engineering the best systems for their requirements. It means looking at customer applications from many angles to find new ways to create value. Whatever the motion and control technology need, Parker has the experience, breadth of product and global reach to consistently deliver. No company knows more about motion and control technology than Parker. For further info call 00800 27 27 5374.



AEROSPACE

Key Markets

- Aircraft engines
- Business & general aviation
- Commercial transports
- Land-based weapons systems
- Military aircraft
- Missiles & launch vehicles
- Regional transports
- Unmanned aerial vehicles

Key Products

- Flight control systems & components
- Fluid conveyance systems
- Fluid metering delivery & atomization devices
- Fuel systems & components
- Hydraulic systems & components
- Inert nitrogen generating systems
- Pneumatic systems & components
- Wheels & brakes



CLIMATE CONTROL

Key Markets

- Agriculture
- Air conditioning
- Food, beverage & dairy
- Life sciences & medical
- Precision cooling
- Processing
- Transportation

Key Products

- CO2 controls
- Electronic controllers
- Filter driers
- Hand shut-off valves
- Hose & fittings
- Pressure regulating valves
- Refrigerant distributors
- Safety relief valves
- Solenoid valves
- Thermostatic expansion valves



ELECTROMECHANICAL

Key Markets

- Aerospace
- Factory automation
- Food & beverage
- Life science & medical
- Machine tools
- Packaging machinery
- Paper machinery
- Plastics machinery & converting
- Primary metals
- Semiconductor & electronics
- Textile
- Wire & cable

Key Products

- AC/DC drives & systems
- Electric actuators
- Controllers
- Gantry robots
- Gearheads
- Human machine interfaces
- Industrial PCs
- Inverters
- Linear motors, slides and stages
- Precision stages
- Stepper motors
- Servo motors, drives & controls
- Structural extrusions



FILTRATION

Key Markets

- Food & beverage
- Industrial machinery
- Life sciences
- Marine
- Mobile equipment
- Oil & gas
- Power generation
- Process
- Transportation

Key Products

- Analytical gas generators
- Compressed air & gas filters
- Condition monitoring
- Engine air, fuel & oil filtration & systems
- Hydraulic, lubrication & coolant filters
- Process, chemical, water & microfiltration filters
- Nitrogen, hydrogen & zero air generators



FLUID & GAS HANDLING

Key Markets

- Aerospace
- Agriculture
- Bulk chemical handling
- Construction machinery
- Food & beverage
- Fuel & gas delivery
- Industrial machinery
- Mobile
- Oil & gas
- Transportation
- Welding

Key Products

- Brass fittings & valves
- Diagnostic equipment
- Fluid conveyance systems
- Industrial hose
- PTFE & PFA hose, tubing & plastic fittings
- Rubber & thermoplastic hose & couplings
- Tube fittings & adapters
- Quick disconnects



HYDRAULICS

Key Markets

- Aerospace
- Aerial lift
- Agriculture
- Construction machinery
- Forestry
- Industrial machinery
- Mining
- Oil & gas
- Power generation & energy
- Truck hydraulics

Key Products

- Diagnostic equipment
- Hydraulic cylinders & accumulators
- Hydraulic motors & pumps
- Hydraulic systems
- Hydraulic valves & controls
- Power take-offs
- Rubber & thermoplastic hose & couplings
- Tube fittings & adapters
- Quick disconnects



PNEUMATICS

Key Markets

- Aerospace
- Conveyor & material handling
- Factory automation
- Food & beverage
- Life science & medical
- Machine tools
- Packaging machinery
- Transportation & automotive

Key Products

- Air preparation
- Compact cylinders
- Field bus valve systems
- Grippers
- Guided cylinders
- Manifolds
- Miniature fluidics
- Pneumatic accessories
- Pneumatic actuators & grippers
- Pneumatic valves and controls
- Rodless cylinders
- Rotary actuators
- Tie rod cylinders
- Vacuum generators, cups & sensors



PROCESS CONTROL

Key Markets

- Chemical & refining
- Food, beverage & dairy
- Medical & dental
- Microelectronics
- Oil & gas
- Power generation

Key Products

- Analytical sample conditioning products & systems
- Fluoropolymer chemical delivery fittings, valves & pumps
- High purity gas delivery fittings, valves & regulators
- Instrumentation fittings, valves & regulators
- Medium pressure fittings & valves
- Process control manifolds



SEALING & SHIELDING

Key Markets

- Aerospace
- Chemical processing
- Consumer
- Energy, oil & gas
- Fluid power
- General industrial
- Information technology
- Life sciences
- Military
- Semiconductor
- Telecommunications
- Transportation

Key Products

- Dynamic seals
- Elastomeric o-rings
- EMI shielding
- Extruded & precision-cut, fabricated elastomeric seals
- Homogeneous & inserted elastomeric shapes
- High temperature metal seals
- Metal & plastic retained composite seals
- Thermal management



ENGINEERING YOUR SUCCESS.



Europe, Middle East, Africa

AE – United Arab Emirates, Dubai
Tel: +971 4 8127100
parker.me@parker.com

AT – Austria, Wiener Neustadt
Tel: +43 (0)2622 23501-0
parker.austria@parker.com

AT – Eastern Europe, Wiener Neustadt
Tel: +43 (0)2622 23501 900
parker.easteurope@parker.com

AZ – Azerbaijan, Baku
Tel: +994 50 2233 458
parker.azerbaijan@parker.com

BE/LU – Belgium, Nivelles
Tel: +32 (0)67 280 900
parker.belgium@parker.com

BY – Belarus, Minsk
Tel: +375 17 209 9399
parker.belarus@parker.com

CH – Switzerland, Etoy
Tel: +41 (0)21 821 87 00
parker.switzerland@parker.com

CZ – Czech Republic, Klecany
Tel: +420 284 083 111
parker.czechrepublic@parker.com

DE – Germany, Kaarst
Tel: +49 (0)2131 4016 0
parker.germany@parker.com

DK – Denmark, Ballerup
Tel: +45 43 56 04 00
parker.denmark@parker.com

ES – Spain, Madrid
Tel: +34 902 330 001
parker.spain@parker.com

FI – Finland, Vantaa
Tel: +358 (0)20 753 2500
parker.finland@parker.com

FR – France, Contamine s/Arve
Tel: +33 (0)4 50 25 80 25
parker.france@parker.com

GR – Greece, Athens
Tel: +30 210 933 6450
parker.greece@parker.com

HU – Hungary, Budapest
Tel: +36 1 220 4155
parker.hungary@parker.com

IE – Ireland, Dublin
Tel: +353 (0)1 466 6370
parker.ireland@parker.com

IT – Italy, Corsico (MI)
Tel: +39 02 45 19 21
parker.italy@parker.com

KZ – Kazakhstan, Almaty
Tel: +7 7272 505 800
parker.easteurope@parker.com

NL – The Netherlands, Oldenzaal
Tel: +31 (0)541 585 000
parker.nl@parker.com

NO – Norway, Asker
Tel: +47 66 75 34 00
parker.norway@parker.com

PL – Poland, Warsaw
Tel: +48 (0)22 573 24 00
parker.poland@parker.com

PT – Portugal, Leca da Palmeira
Tel: +351 22 999 7360
parker.portugal@parker.com

RO – Romania, Bucharest
Tel: +40 21 252 1382
parker.romania@parker.com

RU – Russia, Moscow
Tel: +7 495 645-2156
parker.russia@parker.com

SE – Sweden, Spånga
Tel: +46 (0)8 59 79 50 00
parker.sweden@parker.com

SK – Slovakia, Banská Bystrica
Tel: +421 484 162 252
parker.slovakia@parker.com

SL – Slovenia, Novo Mesto
Tel: +386 7 337 6650
parker.slovenia@parker.com

TR – Turkey, Istanbul
Tel: +90 216 4997081
parker.turkey@parker.com

UA – Ukraine, Kiev
Tel: +380 44 494 2731
parker.ukraine@parker.com

UK – United Kingdom, Warwick
Tel: +44 (0)1926 317 878
parker.uk@parker.com

ZA – South Africa, Kempton Park
Tel: +27 (0)11 961 0700
parker.southafrica@parker.com

North America

CA – Canada, Milton, Ontario
Tel: +1 905 693 3000

US – USA, Cleveland
Tel: +1 216 896 3000

Asia Pacific

AU – Australia, Castle Hill
Tel: +61 (0)2-9634 7777

CN – China, Shanghai
Tel: +86 21 2899 5000

HK – Hong Kong
Tel: +852 2428 8008

IN – India, Mumbai
Tel: +91 22 6513 7081-85

JP – Japan, Tokyo
Tel: +81 (0)3 6408 3901

KR – South Korea, Seoul
Tel: +82 2 559 0400

MY – Malaysia, Shah Alam
Tel: +60 3 7849 0800

NZ – New Zealand, Mt Wellington
Tel: +64 9 574 1744

SG – Singapore
Tel: +65 6887 6300

TH – Thailand, Bangkok
Tel: +662 186 7000-99

TW – Taiwan, Taipei
Tel: +886 2 2298 8987

South America

AR – Argentina, Buenos Aires
Tel: +54 3327 44 4129

BR – Brazil, Sao Jose dos Campos
Tel: +55 800 727 5374

CL – Chile, Santiago
Tel: +56 2 623 1216

MX – Mexico, Apodaca
Tel: +52 81 8156 6000

European Product Information Centre

Free phone: 00 800 27 27 5374

(from AT, BE, CH, CZ, DE, DK, EE, ES, FI, FR, IE, IL, IS, IT, LU, MT, NL, NO, PL, PT, RU, SE, SK, UK, ZA)