



domnick hunter

FILTRATION > the clear liquid or gas obtained after filtration.
verb (filtrated, filtrating) tr & intr to filter. filtration noun.
ETYMOLOGY: 17c. from Latin filtrare to filter.



FILTRATION - PURIFICATION -

PURIFICATION > 1. to make or become pure. 2. to cleanse
something of contaminating or harmful substances. 3. to rid
something of intrusive elements.
ETYMOLOGY: 14c. from Latin purificare, from purus pure.

SEPARATION >
2. the state of being
or line where there
that separates.
ETYMOLOGY: 15c.



OIL-Xplus High Efficiency Compressed Air Filters

www.domnickhunter.com

Compressed air contamination The Problem

Widely used throughout industry, compressed air is a safe, powerful and reliable utility which can be the most important part of any production process. All compressed air systems use atmospheric air, which is highly contaminated with dirt, water vapour, unburned hydrocarbons and bacteria. Additionally, the compressor can add wear particles and oil from its lubricating system. This can also apply to some types of oil free compressors. This oil is degraded, acidic and without lubricating properties. The compressed air distribution system can also add pipescale and rust.

This combination of dirt, oil and water contamination mixes to become an abrasive sludge which rapidly wears pneumatic machinery, blocks valves and corrodes piping systems leading to:

- **Costly air leaks**
- **Breakdown of tools and machinery**
- **Production downtime**
- **Increased maintenance costs**
- **Product Spoilage**
- **Compromised health and safety**
- **Unpleasant working environment**



Typical contamination in a compressed air system

A typical system could introduce in the region of 75,500 litres (20,000 US gallons) of oily, acidic condensate and particulate into the system. Climates with higher humidity will result in even greater volumes of liquid.

These figures are based on a system with a typical 28.3 m³/min (1000 cfm), oil lubricated screw compressor, operating for 4000 hours, in an ambient temperature of 25°C (77°F), 65% RH.



Even clean looking environments contain contamination

OIL-Xplus - The most efficient way to remove compressed air contamination

All of the costly problems associated with compressed air contamination can be avoided by installing domnick hunter OIL-Xplus filters.

With over 40 years unrivalled experience in contamination removal, the domnick hunter reputation is built upon technical excellence, product differentiation, innovation and reliability to consistently deliver customer solutions.

The economic benefit

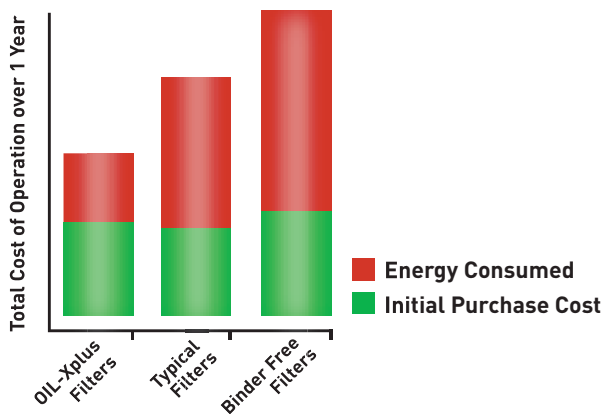

Guaranteed life

All domnick hunter OIL-Xplus high efficiency compressed air filters carry Performance Plus Guarantees. Particulate and aerosol removal filter element performance is guaranteed for 1 year under normal recommended use, and filter housings are guaranteed for 10 years life, under recommended conditions. Further details of the Performance Plus Guarantee are available on request.

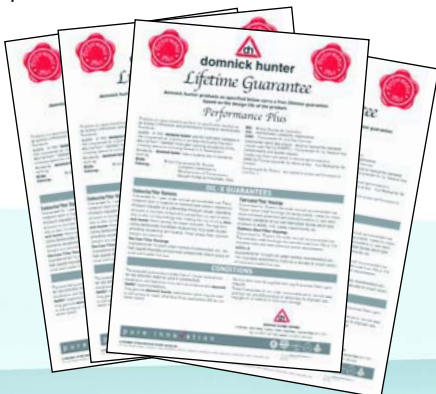

The benefits are obvious

- Protects downstream equipment and processes
- Provides high quality, clean, oil free compressed air to international standards
- Reduced cost of ownership
- Enhanced health and safety
- Filter element performance guaranteed for 12 months
- Suitable for all types of air compressor and compatible with all compressor lubricants
- World-wide sales and support
- Manufactured in accordance with ISO9001



OIL-Xplus – High efficiency compressed air filtration

At the heart of every compressed air filter is the filter element. It's purpose is to provide clean, compressed air between recommended maintenance periods and with the minimum of operating costs.

In 1963 domnick hunter pioneered the use of borosilicate glass microfibre as an effective method of purifying compressed air. Even now, this technical innovation in its highly developed form remains at the forefront of this critical technology.

Research & development

domnick hunter continues to invest considerable resources into researching new filtration materials, media, testing, and manufacturing methods to provide the customer with the ultimate product for compressed air and gas purification.

Quality Assured

All domnick hunter filter elements are manufactured under controlled environmental conditions and subjected to a demanding programme of quality assurance. Our procedures have been assessed by the British Standards Institute and registered to BS EN ISO 9001.

The performance of every domnick hunter OIL-Xplus filter element is backed by a 1 year guarantee

Energy Efficient

The OIL-Xplus range of filters offer the lowest operating cost available by virtue of their low operating pressure drop. In some cases, 50% more energy efficient than typical filters.

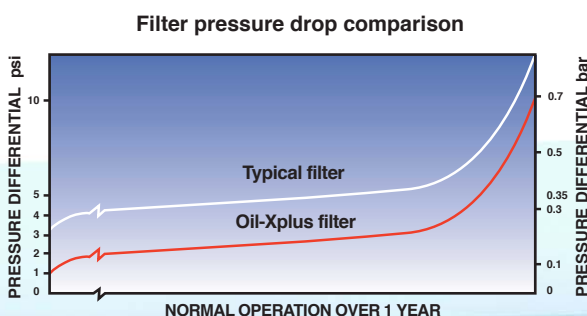

Particulate and Aerosol Removal Filter Elements

Typical compressed air filters 'soak up' oil and water and are said to run in a 'wetted out' or saturated state. This temporarily blocks the path of compressed air through the normally open filter structure and increases the operating pressure drop as the air flow has to force liquids through the fine matrix of the filtration media. This leads to significantly higher energy consumption.

Unlike typical filters, the OIL-Xplus filter media does not soak up liquids, ensuring the available open area is kept to a maximum for dirt entrapment. Liquid aerosols coalesce within the anti re-entrainment barrier and fall into the filter bowl to be discharged via the drain.

Solid particulate is captured and held within the open area of the filter media, eventually increasing the differential pressure to a point where it is more economical to replace the filter element.

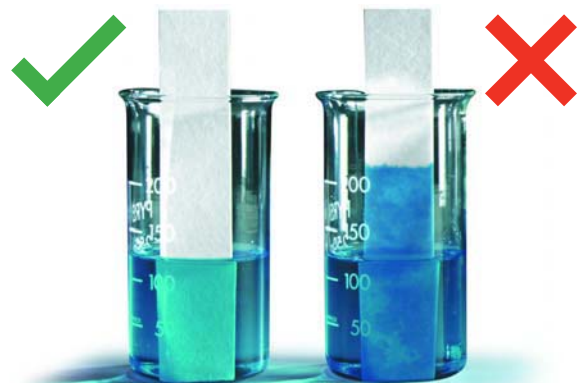

OIL-Xplus filter media actively repels oil and water Typical filter medias soak up oil and water

Oil Vapour Removal Elements

Whilst mechanical filtration is capable of removing extremely fine liquids or solid particles, it cannot remove gaseous contaminants such as oil vapours or odours. To do this, we must employ adsorption techniques. Activated carbon, having an affinity for oil vapour molecules and an extremely high surface area is used for this.

OIL-Xplus high-efficiency filter elements



Air tight positive 'O' ring seal
Prevents contamination by-pass.



Support media
For added strength and integral pre-filtration.

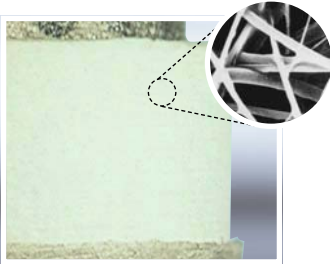

96% voids volume
Gives high dirt holding capacity and provides 12 months life with lowest available energy costs.



Stainless steel inner and outer support cylinders
Provides maximum strength.

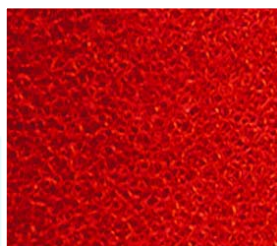

Anti re-entrainment barrier
Prevents oil / water carryover and is compatible with a wide range of lubricants.

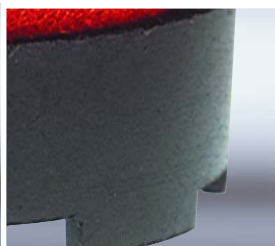

Chemical resistant
Tough corrosion resistant end caps withstand the worst compressed air conditions.

Regular Filter Element changes are essential

Protecting downstream equipment and processes is essential. This can only be achieved by ensuring that filter elements are replaced every year or earlier if the indicator / monitor changes to red.



Failure to replace filter elements will result in reduced production performance, degrading air quality and increased running costs.

domnick hunter particulate and aerosol removal filter elements are guaranteed for one year under normal recommended use.

Replacing your filter elements with genuine domnick hunter parts offers many benefits:

- **High quality compressed air always**
- **Continued protection of downstream equipment and processes**
- **Maintains low running costs**
- **Extends 12 months performance plus guarantee**
- **Peace of mind**

OIL-Xplus – Designed for performance

1/4" to 4"
ported connections



FILTRATION

ON

SEPARATION

A fixing kit connects two filters in series saving space.



Differential pressure indicator (DPI) is fitted as standard on filters up to 1/2" port size (except AC/ACS/AX filters).



Differential pressure monitor fitted as standard on filters 3/4" and larger. (except AC/ACS/AX grades).



Calibrated change over point.



Sight glass.



Bleed valve for rapid depressurisation and aut drain function check.



Automatic drain valve is standard so collected condensate is always removed. (manual drain only on models AR, AAR, ACS).



Pressure relief hole gives an audible warning if any attempt is made to remove filter bowl whilst under pressure.



Rapid maintenance.

Maximum corrosion protection

Corrosion protected with Alocrom treatment and tough epoxy paint finish for extra long life.



Rapid corrosion of untreated aluminium.

No corrosion with Alocrom treatment.

DN40 to DN300
flanged connections



FILTRATION

SEPARATION



Heavy duty automatic drain as standard allows continuous removal of liquids collected by mainline filters.



Optional ED2000 series electronic level sensing drains available



OIL-Xplus fabricated filters are available to many international design standards.



Differential pressure monitor kit allows easy monitoring of filter element condition.

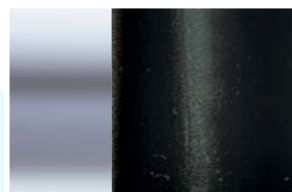

Internal and external tough epoxy coating gives corrosion resistance and long life to filter housings.



Hinged lower body flange makes maintenance by one person easy. Fabricated filters use easy to fit filter elements.

High Quality Compressed Air from Generation to Application

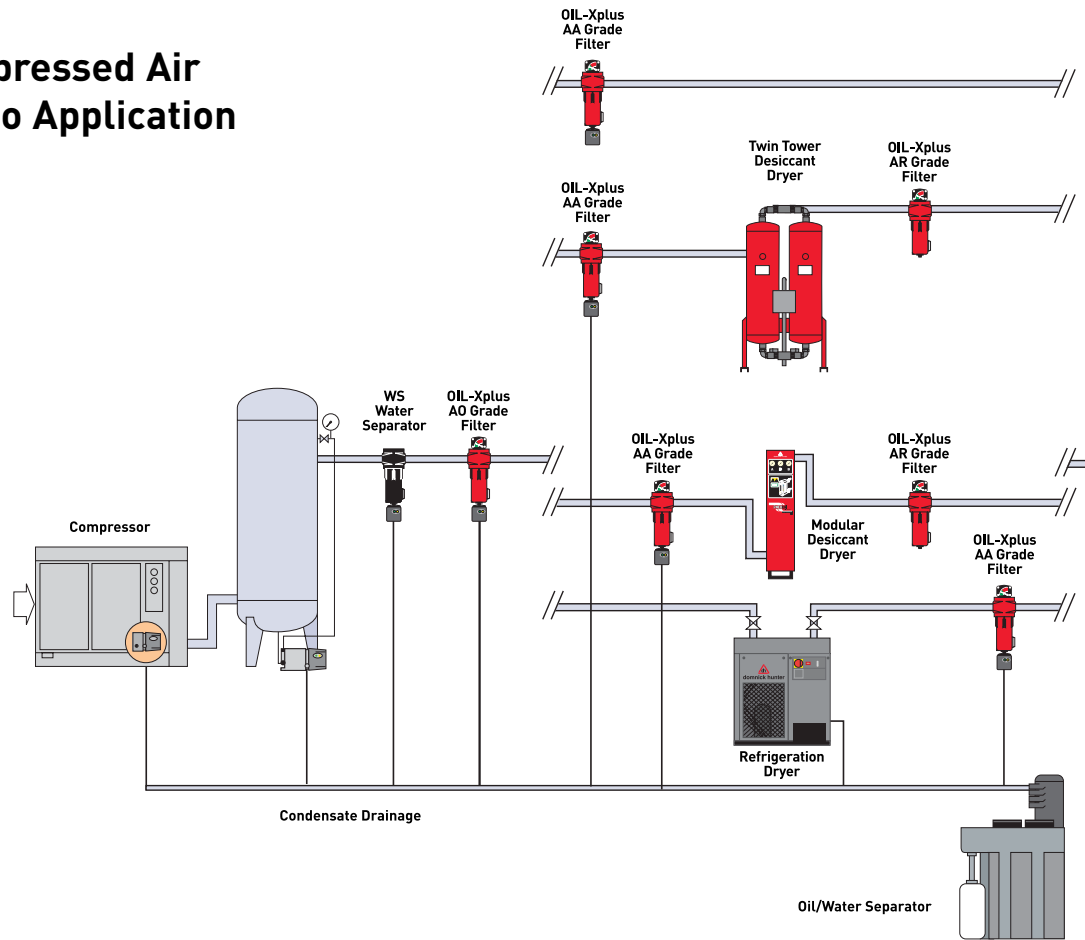

Compressor room

Filtration grades

GRADE WS

Water Separators

For the removal of up to 99% of bulk liquid contamination. *(For further information refer to publication ref: 17 400 4413)*

GRADE PF

Coarse Pre-Filtration

Particle removal down to : 25 microns, including water and oil aerosols.

GRADE AO

High Efficiency General Purpose Protection

Particle removal down to : 1 micron, including water and oil aerosols.
Maximum remaining oil aerosol content: 0.6 mg/m³ at 21°C / 0.5 ppm(w) at 70°F.

GRADE AA

High Efficiency Oil Removal Filtration

(Precede with Grade AO filter)
Particle removal down to: 0.01 micron, including water and oil aerosols. Maximum remaining oil aerosol content : 0.01 mg/m³ at 21°C / 0.01 ppm(w) at 70°F.

GRADE AX

Ultra High Efficiency Filtration

(Precede with Grade AO filter)
Particle removal down to : 0.01 micron, including water and oil aerosols. Maximum remaining oil aerosol content : 0.001 mg/m³ at 21°C / 0.001 ppm(w) at 70°F.

GRADE AR

General Purpose Dust Filtration

Dry particle removal down to : 1 micron

GRADE AAR

High Efficiency Dust Filtration

Dry particle removal down to : 0.01 micron

GRADE AC & ACS

Oil Vapour & Odour Removal

(Precede Grade ACS with Grade AA filter)
Maximum remaining oil vapour content : 0.003 mg/m³ at 21°C / 0.003 ppm(w) at 70°F.
(Grade AC filter combines AA and AC Grades)

The quality of air required throughout a typical compressed air system can vary. The extensive range of filtration grades from domnick hunter is ideal for both centralised and decentralised compressed air systems. This allows the user to specify the air quality for each application, from general purpose ring main protection to critical point of use clean dry air (CDA) systems.

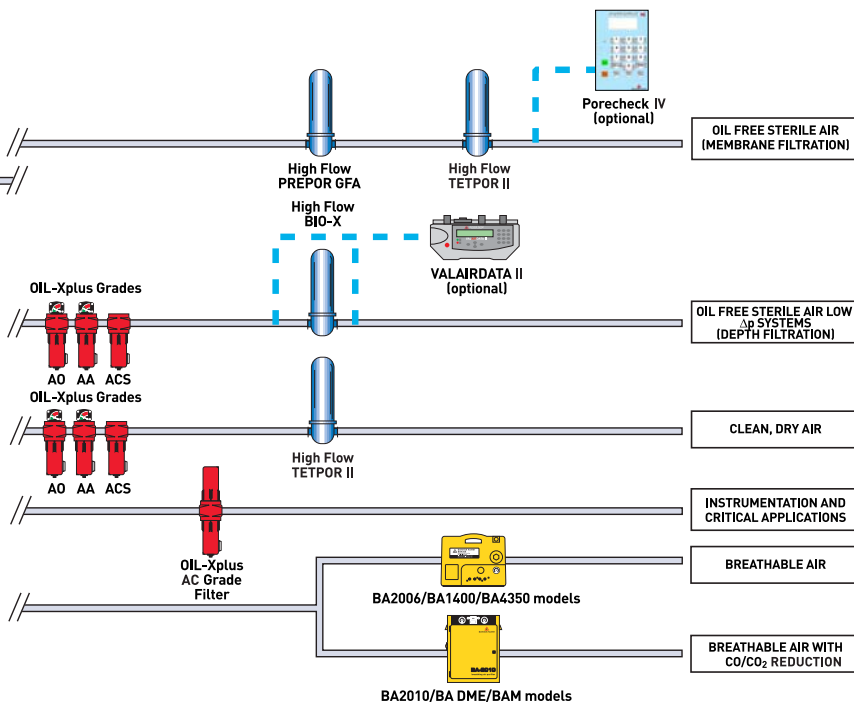

Application

HIGH FLOW BIO-X

Sterile Air

Removal of bacteria, viruses and particulate.
 (For further information refer to publication ref: 17 400 4726)

HIGH FLOW TETPOR

Absolute Filtration

Full retention of bacteria, viruses and particulate.
 (For further information refer to publication ref: 17 950 10002)

TETPOR Air Compressed Air Quality & Product Selection

COMPRESSED AIR QUALITY TO ISO 8573.1

The international standard for compressed air quality provides a simple system of classification for the three main contaminants present in any compressed air system - DIRT, WATER and OIL. To specify the quality class required for a particular application, simply list the class for each contaminant in turn.

Class	Solid Particle Maximum number of particles per m ³			Water Pressure Dewpoint °C	Oil (incl. vapour) mg/m ³
	0.1-0.5micron	0.5-0.1 micron	1.0-5.0 micron		
1	100	1	0	-70	0.01
2	10,000	1,000	10	-40	0.1
3	-	10,000	500	-20	1
4	-	-	1,000	3	5
5	-	-	20,000	7	-
6	-	-	-	10	-

Selection Criteria

Stated flows are at 7 bar g (100 psi g) ANR conditions. For flows at other pressures apply the correction factor shown.

Filter Type	Port Size	Flow rates			Replacement Element Kit	No	Line Pressure		Correction Factor
		Nm ³ /min	Nm ³ /hr	scfm			bar g	psi g	
(grade) 0003G	8mm Push Fit	0.18	11	6	K003 (grade)	1	1	15	0.38
(grade) 0009G	G¼	0.53	32	19	K009 (grade)	1	2	29	0.53
(grade) 0009GP	G¾	0.53	32	19	K009 (grade)	1	3	44	0.65
(grade) 0017G	G¾	1.02	61	36	K017 (grade)	1	4	58	0.76
(grade) 0017GP	G½	1.02	61	36	K017 (grade)	1	5	73	0.85
(grade) 0030G	G½	1.80	108	64	K030 (grade)	1	6	87	0.93
(grade) 0030GP	G¾	1.80	108	64	K030 (grade)	1	7	100	1.00
(grade) 0058G	G¾	3.60	216	127	K058 (grade)	1	8	116	1.07
(grade) 0080G	G1	4.80	288	170	K145 (grade)	1	9	131	1.13
(grade) 0125G	G1¼	7.20	432	254	K145 (grade)	1	10	145	1.19
(grade) 0145G	G1½	8.70	522	307	K145 (grade)	1	11	160	1.25
(grade) 0205G	G1½	12.00	720	424	K220 (grade)	1	12	174	1.31
(grade) 0220G	G2	13	792	466	K220 (grade)	1	13	189	1.36
(grade) 0330G	G2	20	1188	699	K330 (grade)	1	14	203	1.41
(grade) 0405G	G2½	24	1440	848	K430 (grade)	1	15	218	1.46
(grade) 0430G	G3	26	1548	911	K430 (grade)	1	16	232	1.51
(grade) 0620G	G3	37	2232	1314	K620 (grade)	1	17	247	1.56
(grade) 1000G	G4	60	3600	2119	K330 (grade)	3	18	261	1.60
(grade) 0205FNT	DN40	12	720	424	K220 (grade) NT	1	19	275	1.65
(grade) 0330FNT	DN50	20	1188	669	K330 (grade) NT	1	20	290	1.70
(grade) 0620FNT	DN80	37	2232	1314	K620 (grade) NT	1			
(grade) 1000FNT	DN100	60	3600	2119	K330 (grade) NT	3			
(grade) 1300FNT	DN100	78	4680	2755	K330 (grade) NT	4			
(grade) 1950FNT	DN150	117	7020	4132	K330 (grade) NT	6			
(grade) 3250FNT	DN200	195	11700	6886	K330 (grade) NT	10			
(grade) 5200FNT	DN250	312	18720	11018	K330 (grade) NT	16			
(grade) 7800FNT	DN300	468	28080	16527	K330 (grade) NT	24			
AC-0006G	G¼	0.37	22	13	K009AA & K006AC	1*			
AC-0013G	G¾	0.78	47	27	K017AA & K013AC	1*			
AC-0025G	G½	1.50	90	53	K030AA & K025AC	1*			
AC-0040G	G¾	2.40	144	84	K058AA & K040AC	1*			
AC-0065G	G1	3.90	234	136	K145AA & K065AC	1*			
AC-0085G	G1¼	5.10	306	178	K145AA & K085AC	1*			

When ordering a filter for pressures above 16 bar g (232 psi g) the suffix X should be added to the product code. e.g. AA-0058GX.

*Grade AA and Grade AC elements required for double stage filter.

To find the correction factors for pressures other than 7bar g (100 psi g), use the following equation

$$\text{e.g. Correction factor} = \sqrt{\frac{\text{System Operating Pressure}}{\text{Nominal pressure}}} = \sqrt{\frac{8.5 \text{ bar g}}{7 \text{ bar g}}} = 1.10$$

Therefore, for 8.5 bar g multiply nominal flow rate by 1.10

Technical Data

Filter Types	Maximum Operating Pressure	OIL-Xplus Filter Grades	Maximum Recommended** Operating Temperature	Minimum Recommended** Operating Temperature
003G	10.5 bar g (150 psi g)	PF/ AO/AR AA/AAR AX	66°C (150°F)	1.5°C (35°F)
0009G - 7800F with Autodrain	16 bar g (232 psi g)	AC/ACS	30°C (86°F)	1.5°C (35°F)
0009G - 7800F with Manual Drain	20 bar g (290 psi g)			

**High Temperature Filters / Elements are available for temperature in excess of 66°C (150°F) [publication ref: 17 400 4421 available at www.domnickhunter.com]

Technical Specifications

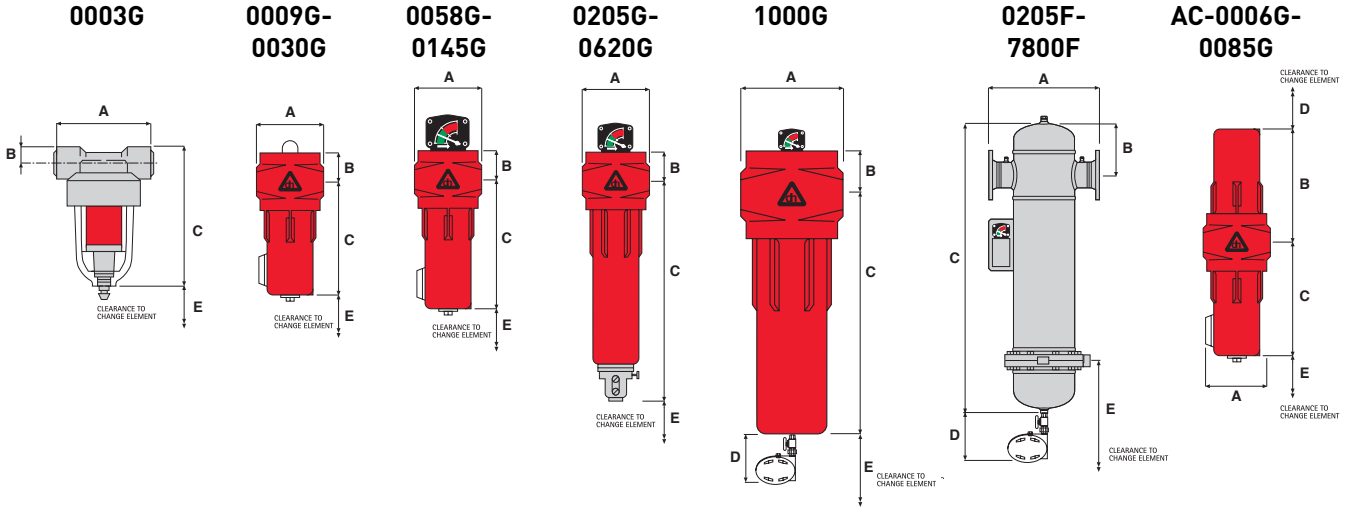

Weights and Dimensions

Filter Type	Port Size	A		B		C		D		E		Net Weight	
		mm	ins	mm	ins	mm	ins	mm	ins	mm	ins	kg	lbs
(grade) 0003G	8mm Push Fit	58	2.3	9.75	0.4	89	3.5	-	-	45	1.8	0.1	0.2
(grade) 0009G	G1/4	76	3.0	34.5	1.4	133	5.2	-	-	70	2.8	0.5	1.2
(grade) 0009GP	G3/8	76	3.0	34.5	1.4	133	5.2	-	-	70	2.8	0.5	1.2
(grade) 0017G	G3/8	89	3.5	42	1.7	158	6.2	-	-	95	3.7	1	2.2
(grade) 0017GP	G1/2	89	3.5	42	1.7	158	6.2	-	-	95	3.7	1	2.2
(grade) 0030G	G1/2	89	3.5	42	1.7	194	7.6	-	-	130	5.1	1.1	2.4
(grade) 0030GP	G3/4	89	3.5	42	1.7	194	7.6	-	-	130	5.1	1.1	2.4
(grade) 0058G	G1/4	120	4.7	58	2.3	251	9.9	-	-	172	6.8	2.4	5.3
(grade) 0080G	G1	120	4.7	58	2.3	351	13.8	-	-	272	10.7	2.9	6.4
(grade) 0125G	G1 1/4	120	4.7	58	2.3	351	13.8	-	-	272	10.7	2.9	6.4
(grade) 0145G	G1 1/2	120	4.7	58	2.3	351	13.8	-	-	272	10.7	2.9	6.4
(grade) 0205G	G1 1/2	160	6.3	66.5	2.6	509.6	20.1	-	-	320	12.6	6.6	14.5
(grade) 0220G	G2	160	6.3	66.5	2.6	509.6	20.1	-	-	320	12.6	6.6	14.5
(grade) 0330G	G2	160	6.3	66.5	2.6	816	32.1	-	-	625	24.6	10.8	23.8
(grade) 0405G	G2 1/2	202	8.0	79	3.1	602	23.7	-	-	400	15.7	12.5	27.6
(grade) 0430G	G3	202	8.0	79	3.1	602	23.7	-	-	400	15.7	12.5	27.6
(grade) 0620G	G3	202	8.0	79	3.1	844	33.2	-	-	625	24.6	17.5	38.58
(grade) 1000G	G4	420	16.5	82	3.2	1095	43.1	335	13.2	570	22.4	44.5	98
(grade) 0205FNT	DN40	304	12	115	4.5	624	24.6	335	13.2	350	13.8	29	64
(grade) 0330FNT	DN50	304	12	120	4.7	934	36.8	335	13.2	650	25.6	37	81
(grade) 0620FNT	DN80	390	15.4	177	7	1077	42.4	335	13.2	650	25.6	64	141
(grade) 1000FNT	DN100	450	17.7	201	7.9	1140	44.9	335	13.2	650	25.6	95	209
(grade) 1300FNT	DN100	500	19.7	230	9	1220	48	335	13.2	650	25.6	135	297
(grade) 1950FNT	DN150	580	22.8	273	10.7	1294	50.9	335	13.2	650	25.6	177	389
(grade) 3250FNT	DN200	750	29.5	361	14.2	1519	59.8	335	13.2	650	25.6	368	810
(grade) 5200FNT	DN250	740	29.1	410	16.1	1684	66.3	335	13.2	800	31.5	515	1133
(grade) 7800FNT	DN300	1000	39.4	485	19.1	1777	70	335	13.2	850	33.5	684	1505
AC-0006G	G1/4	76	2.9	133	5.24	133	5.24	70	2.75	70	2.75	1.0	2.2
AC-0013G	G3/8	89	3.5	158	6.22	158	6.22	95	3.74	95	3.74	1.2	2.6
AC-0025G	G1/2	89	3.5	194	7.76	194	7.76	95	3.74	130	5.18	1.4	3.1
AC-0040G	G3/4	120	4.7	251	9.88	251	9.88	125	4.92	172	6.77	3.2	7.1
AC-0065G	G1	120	4.7	251	9.88	351	13.82	125	4.92	272	10.71	3.7	8.2
AC-0085G	G1 1/4	120	4.7	351	13.82	351	13.82	225	8.86	272	10.71	3.8	8.4

FILTRATION - PURIFICATION - SEPARATION

dh, domnick hunter, OIL-X and PNEUDRI are registered trademarks of domnick hunter limited.

domnick hunter limited has a continuous policy of product development and although the Company reserves the right to change specifications, it attempts to keep customers informed of any alterations. This publication is for general information only and customers are requested to contact our Industrial Division Sales Department for detailed information and advice on a products suitability for specific applications. All products are sold subject to the Company's standard conditions of sale.



domnick hunter limited
Dukesway, Team Valley Trading Estate,
Gateshead, Tyne and Wear,
England NE11 0PZ
Tel: +44 (0)191 402 9000
Telefax: +44 (0)191 482 6296
<http://www.domnickhunter.com>

www.domnickhunter.com

a member of the domnick hunter group plc



Copyright domnick hunter limited 2003
Publication Reference: 04 09/03 Rev. 012
Stock No. 17 400 4404