



aerospace
 climate control
 electromechanical
 filtration
 fluid & gas handling
 hydraulics
 pneumatics
 process control
 sealing & shielding



Parker Hannifin Corporation
Mitos Biotech Business Unit
 700 Schell Lane
 Phoenixville, PA 19460
 phone 610 933 1600
 fax 610 933 1673
 email mitos.sales@parker.com
www.mitostech.com



Mitos Biotech Business Unit

Custom Engineered Bioprocess Systems
 and Components
 Catalog 3700 | June 2010



ENGINEERING YOUR SUCCESS.



About Mitos

Mitos Technologies Inc is now Mitos Biotech, a Business Unit of Parker Hannifin. As a part of the Parker Family, Mitos Biotech now has access to greatly expanded resources, products and technologies.

Parker is the world's leading manufacturer of motion and control technologies. With over 50,000 employees world wide, supplying over 1,000,000 products in over 50 countries. Parker's expertise spans a wide range of markets and technologies including; Aerospace, Climate Control, Filtration, Electromechanical, Fluid & Gas Handling, Hydraulics, Pneumatics, Process Control and Sealing & Shielding. We are your partner in designing and delivering innovative motion and control products and systems.

Our focus is on our customers, by improving their productivity and profitability, we create a cleaner, more efficient future for everyone. Parker delivers value by providing Premier Customer Service, Empowered Employees, Innovative Products, System Solutions and Strong Distribution. Parker is uniquely positioned to address the challenges of mankind in the areas of Food, Water, Infrastructure, Transportation, Life Sciences, Environment, Defense and Energy. How can we help you?

ENGINEERING YOUR SUCCESS.

The Mitos Biotech Business Unit is a focused niche provider of single-use technologies and complementary products for the biopharmaceutical industry. Mitos Biotech helped lead the way in the development of products and services that have revolutionized the safe and efficient manufacturing of biopharmaceutical products. Our expertise includes bioprocess containers, molded manifold assemblies, filtration products, valves, tubing, aseptic connectors, hose assemblies and mixing systems. Mitos Biotech's services include system design, PERFECTFIT service, gamma irradiation and customized learning forums.



Parker Hannifin Corporation
Mitos Biotech Business Unit
700 Schell Lane
Phoenixville, PA 19460
phone 610 933 1600
fax 610 933 1673
email mitos.sales@parker.com
www.mitostech.com

OFFER OF SALE

The items described in this document and other documents and descriptions provided by Parker Hannifin Corporation, its subsidiaries and its authorized distributors ("Seller") are hereby offered for sale at prices to be established by Seller. This offer and its acceptance by any customer ("Buyer") shall be governed by all of the following Terms and Conditions. Buyer's order for any item described in its document, when communicated

- 1. Terms and Conditions.** Seller's willingness to offer Products, or accept an order for Products, to or from Buyer is expressly conditioned on Buyer's assent to these Terms and Conditions and to the terms and conditions found on-line at www.parker.com/salesterms/. Seller objects to any contrary or additional term or condition of Buyer's order or any other document issued by Buyer.
- 2. Price Adjustments; Payments.** Prices stated on the reverse side or preceding pages of this document are valid for 30 days. After 30 days, Seller may change prices to reflect any increase in its costs resulting from state, federal or local legislation, price increases from its suppliers, or any change in the rate, charge, or classification of any carrier. The prices stated on the reverse or preceding pages of this document do not include any sales, use, or other taxes unless so stated specifically. Unless otherwise specified by Seller, all prices are F.O.B. Seller's facility, and payment is due 30 days from the date of invoice. After 30 days, Buyer shall pay interest on any unpaid invoices at the rate of 1.5% per month or the maximum allowable rate under applicable law.
- 3. Delivery Dates; Title and Risk; Shipment.** All delivery dates are approximate and Seller shall not be responsible for any damages resulting from any delay. Regardless of the manner of shipment, title to any products and risk of loss or damage shall pass to Buyer upon tender to the carrier at Seller's facility (i.e., when it's on the truck, it's yours). Unless otherwise stated, Seller may exercise its judgment in choosing the carrier and means of delivery. No deferment of shipment at Buyers' request beyond the respective dates indicated will be made except on terms that will indemnify, defend and hold Seller harmless against all loss and additional expense. Buyer shall be responsible for any additional shipping charges incurred by Seller due to Buyer's changes in shipping, product specifications or in accordance with Section 13, herein.
- 4. Warranty.** Seller warrants that the Products sold hereunder shall be free from defects in material or workmanship for a period of twelve months from the date of delivery to Buyer or 2,000 hours of normal use, whichever occurs first. This warranty is made only to Buyer and does not extend to anyone to whom Products are sold after purchased from Seller. The prices charged for Seller's products are based upon the exclusive limited warranty stated above, and upon the following disclaimer: **DISCLAIMER OF WARRANTY: THIS WARRANTY COMPRISES THE SOLE AND ENTIRE WARRANTY PERTAINING TO PRODUCTS PROVIDED HEREUNDER. SELLER DISCLAIMS ALL OTHER WARRANTIES, EXPRESS AND IMPLIED, INCLUDING MERCHANTABILITY AND FITNESS FOR A PARTICULAR PURPOSE.**

- 5. Claims; Commencement of Actions.** Buyer shall promptly inspect all Products upon delivery. No claims for shortages will be allowed unless reported to the Seller within 10 days of delivery. No other claims against Seller will be allowed unless asserted in writing within 60 days after delivery or, in the case of an alleged breach of warranty, within 30 days after the date within the warranty period on which the defect is or should have been discovered by Buyer. Any action based upon breach of this agreement or upon any other claim arising out of this sale (other than an action by Seller for any amount due to Seller from Buyer) must be commenced within thirteen months from the date of tender of delivery by Seller or, for a cause of action based upon an alleged breach of warranty, within thirteen months from the date within the warranty period on which the defect is or should have been discovered by Buyer.
- 6. LIMITATION OF LIABILITY.** UPON NOTIFICATION, SELLER WILL, AT ITS OPTION, REPAIR OR REPLACE A DEFECTIVE PRODUCT, OR REFUND THE PURCHASE PRICE. IN NO EVENT SHALL SELLER BE LIABLE TO BUYER FOR ANY SPECIAL, INDIRECT, INCIDENTAL OR CONSEQUENTIAL DAMAGES ARISING OUT OF, OR AS THE RESULT OF, THE SALE, DELIVERY, NON-DELIVERY, SERVICING, USE OR LOSS OF USE OF THE PRODUCTS OR ANY PART THEREOF, OR FOR ANY CHARGES OR EXPENSES OF ANY NATURE INCURRED WITHOUT SELLER'S WRITTEN CONSENT, EVEN IF SELLER HAS BEEN NEGLIGENT, WHETHER IN CONTRACT, TORT OR OTHER LEGAL THEORY. IN NO EVENT SHALL SELLER'S LIABILITY UNDER ANY CLAIM MADE BY BUYER EXCEED THE PURCHASE PRICE OF THE PRODUCTS.
- 7. Contingencies.** Seller shall not be liable for any default or delay in performance if caused by circumstances beyond the reasonable control of Seller.
- 8. User Responsibility.** The user, through its own analysis and testing, is solely responsible for making the final selection of the system and Product and assuring that all performance, endurance, maintenance, safety and warning requirements of the application are met. The user must analyze all aspects of the application and follow applicable industry standards and Product information. If Seller provides Product or system options, the user is responsible for determining that such data and specifications are suitable and sufficient for all applications and reasonably foreseeable uses of the Products or systems.
- 9. Loss to Buyer's Property.** Any designs, tools, patterns, materials, drawings, confidential information or equipment furnished by Buyer or any other items which become Buyer's property, may be considered obsolete and may be destroyed by Seller after two consecutive years have elapsed without Buyer placing an order for the items which are manufactured using such property. Seller shall not be responsible for any loss or damage to such property while it is in Seller's possession or control.



WARNING - USER RESPONSIBILITY

FAILURE OR IMPROPER SELECTION OR IMPROPER USE OF THE PRODUCTS DESCRIBED HEREIN OR RELATED ITEMS CAN CAUSE DEATH, PERSONAL INJURY AND PROPERTY DAMAGE.

- This document and other information from Parker-Hannifin Corporation, its subsidiaries and authorized distributors provide product or system options for further investigation by users having technical expertise.
- The user, through its own analysis and testing, is solely responsible for making the final selection of the system and components and assuring that all performance, endurance, maintenance, safety and warning requirements of the application are met. The user must analyze all aspects of the application, follow applicable industry standards, and follow the information concerning the product in the current product catalog and in any other materials provided from Parker or its subsidiaries or authorized distributors.
- To the extent that Parker or its subsidiaries or authorized distributors provide component or system options based upon data or specifications provided by the user, the user is responsible for determining that such data and specifications are suitable and sufficient for all applications and reasonably foreseeable uses of the components or systems.

Mitos Biotech Products

Table of Contents:

Introduction	Page 1
PoGo Mixing System	Page 2
SpinBag Mixing	Page 4
FreeFlow Valves	Page 6
FreeFlow Sampling Valves	Page 8
DuraPure Bioprocess Bags	Page 10
Tubing/Hose	Page 11
Molded Silicone Manifolds	Page 16
Molded & Stainless Fittings	Page 18
Connectors	Page 19
Stainless Steel Components	Page 20
mitos i-cap	Page 21
i-logic gasket systems	Page 22
CLEAR-mark	Page 23
Assembly & Gamma Services	Page 24
Glossary of Terms	Page 25

Look for these symbols to know if products. . .



Meet USP Class VI,
cytotoxicity &
physicochemical
standards



Have a lot
number that will
not rub, peel or
fall off



Are free of
animal,
microbiological
and cell culture



Comply with total
organic carbon
standards
(Low TOC)

Our symbol system easily identifies the important qualities of our high-purity products. These symbols indicate if a product is validated, lot etched, not animal-derived, or post-cured for low Total Organic Carbon.

Mitos Biotech Business Unit

Your Trusted Source for Innovative, Cost Effective, Custom Engineered Bioprocess Systems & Components

Trusted Partner

Mitos Biotech understands the challenges and needs of the biopharmaceutical market. Our products are aimed to minimize the potential risk and maintain flexibility as product development moves from R&D to full commercial production. We integrate currently validated components into a fully validated and ready-to-use system solution. Mitos Biotech is backed by Parker Hannifin (NYSE PH), one of the world's premier motion & control technologies suppliers with extensive global footprint and a solid record of financial performance.

Custom Engineering

Within the Biopharmaceutical market, one size does not fit all. Mitos Biotech efficiently provides custom engineered products and systems by using the modular products in custom configurations to meet your specific application needs.

Innovation

Mitos Biotech continues to provide innovative products, services and system solutions. Whether it's the robust PoGo mixer, patented Free Flow valves, fully configurable DuraPure bioprocess container systems, or safety enhancing i-caps, our goal is to deliver on Parker's promise to "Engineer Your Success".

System Solutions

Having Mitos Biotech as your system supplier and integrator allows you the freedom to focus on your core competency. Our single-use integrated systems are provided with certificates of conformance, gamma irradiated, and are ready to for installation. Our team focuses on providing ready-to-use system solutions efficiently.

Components

Partnering with Mitos Biotech provides access to a complete roster of discrete components that can easily and seamlessly be incorporated into virtually any design process and system. These products and components are designed and manufactured specifically to meet the strict requirements of the biotech and biopharmaceutical market and are guaranteed to meet your needs.

Value Focused

Mitos Biotech understands that there is increased cost pressure on all levels of any organization to secure the best possible product at the most cost effective price. That is why we have always and will continue to strive to bring value to our customers by employing Lean methodology and a continuous improvement mindset in all aspects of our business. Our goal is to provide supply chain security and competitive pricing at every stage of the process.



Filters & Connectors



Bags & Vessels



Sampling Valves



Single-Use Mixing Units



Tubing & Hose



Molded Manifolds

PoGo™ G2

Mixing System (Patent Pending)

Single-Use Mixing System for Cell Culture, Media and Buffers



Programmable Mixing with Reciprocating Action

Mitos Biotech's robust PoGo mixing system uses a fully programmable reciprocating motion that combines fast efficient mixing with low shear effect. Multiple mixing disks on a common shaft create a multi-phased mixing process that eliminates dead spots to ensure fluids and solids remain in suspension.

The PoGo mixer frame is constructed of 304 Stainless Steel and uses rugged Parker CTC actuation and control technology. The easy to use color touch screen provides a wide range of functions and control features. The electronics come standard with expansion capabilities for additional user specified inputs and outputs.

The PoGo mixing system uses detachable mixing tanks that allow quick change from batch to batch. The sturdy rolling LDPE tanks can be used as open top mixers or combine with Mitos Biotech's innovative DuraPure sealed single-use mixing chambers.

Mixing chambers can be supplied gamma irradiated and in a variety of materials and custom port configurations to match customer specific requirements.



PoGo™ G2 Mixing System Features

- Efficient, low shear reciprocating mixing action
- Fully programmable mixing action via easy-to-use color touch screen
- Small footprint to save floor space
- Custom configurable DuraPure Single-Use mixing chambers
- Detachable mixing tanks for quick batch-to-batch processing
- NEMA 4 enclosures for wash down applications
- 200 Liter standard – other sizes custom engineered

PoGo G2 Mixing System



Display Features

- Full Color monitor displays instructions and/or company information.
- Manual or programmable operation modes.
- Programmed mode offers memory up to 99 recipes that can be individually named and stored for instant recall and use.
- Variable stroke lengths can be set at various starting and stopping points along the 5" stroke range.
- Remote operation and monitoring via network connection allows the mixer to be controlled from an outside location

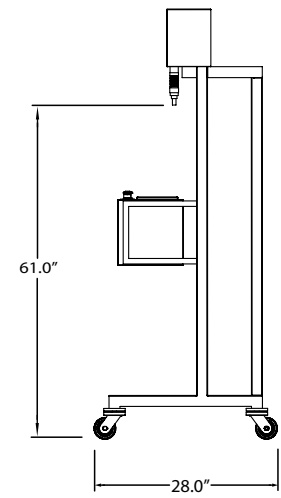
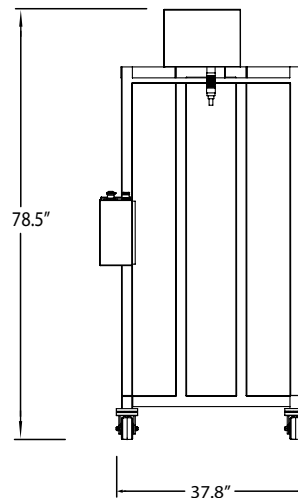
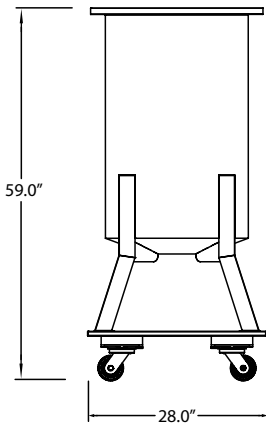

Frame and Tank Specifications

- Rugged polished 304 stainless steel frame & enclosures
- NEMA 4 rated electronics
- LDPE mixing tank
- Lockable rotating casters

Drive Unit and Controller Specifications

- Ethernet connectivity for network or remote control
- Color touch screen interface
- User programmable
- Custom PoGo motion profiles
- Internal memory for recalling stored recipes
- Multiple security layers control access to proprietary recipes
- Linear actuator
- Servo ball screw drive

Materials of Construction	
Tank	Polyethylene
Casters	Urethane & Stainless Steel

Materials of Construction	
Frame	304 Stainless Steel
Casters	Urethane & Stainless Steel

SpinBag™ (Patent Pending)

Table Top Mixing System

Efficient Small Volume Mixing and Stirring with Disposable Bag Technology

Mitos Biotech's compact SpinBag system offers a simple solution to the cost, storage, and cleaning challenges of traditional rigid bottles and spinner flasks.

Each 3D SpinBag is constructed of validated DuraPure film with a specialty coated magnetic stir bar inside. When placed on the mixing plate, the bar rotates to create a vortex of motion to thoroughly mix or stir the fluid contents. The easy-to-operate, programmable control panel lets you adjust the speed and set the temperature.

Bags store flat, occupying less space than bottles or shatter-prone glass flasks. The versatile mixing plate drive unit has a small footprint and is compatible with SpinBags in a variety of volumes and port configurations.



SpinBag Features

- Universal mixing plate and stand fits 2L to 20L bags
- Small 12" X 12" footprint with integrated heater and variable speed control
- 3D SpinBags store flat and can be ordered with custom port configurations and pre-sterilized options
- Ideal for cell culture, media, buffer, and suspension/re-suspension applications

SpinBag System



SpinBag Specifications	
DuraPure Single-Use Bag Volume Options	Available in 2L, 5L, 10L, 20L Sizes
DuraPure Single-Use Bag Material Validations	<ul style="list-style-type: none"> Meets USP Class VI Testing Muscle Implantation Testing cGMP Manufacturing
Port Location Options	Custom Solutions Available

Drive Unit Specifications	
Physical Features	<ul style="list-style-type: none"> Universally compatible with SpinBags, sizes 2L to 20L Stainless steel bag support stand 12" X 12" footprint (10.5" X 10.5" X 1" plate) Remote probe connection RS232 port to output time, speed, and temperature data to a PC 120 Volts, 10.1 Amps, 1210 Watts, single phase
Program Features	<ul style="list-style-type: none"> Speed settings from 0 to 1200 rpm Temperature settings from 0 to 70 C Program up to four presets for speed and temperature Pause button for speed and temperature Programmable timer for 1, 2, 4, 8, and 12 hour durations

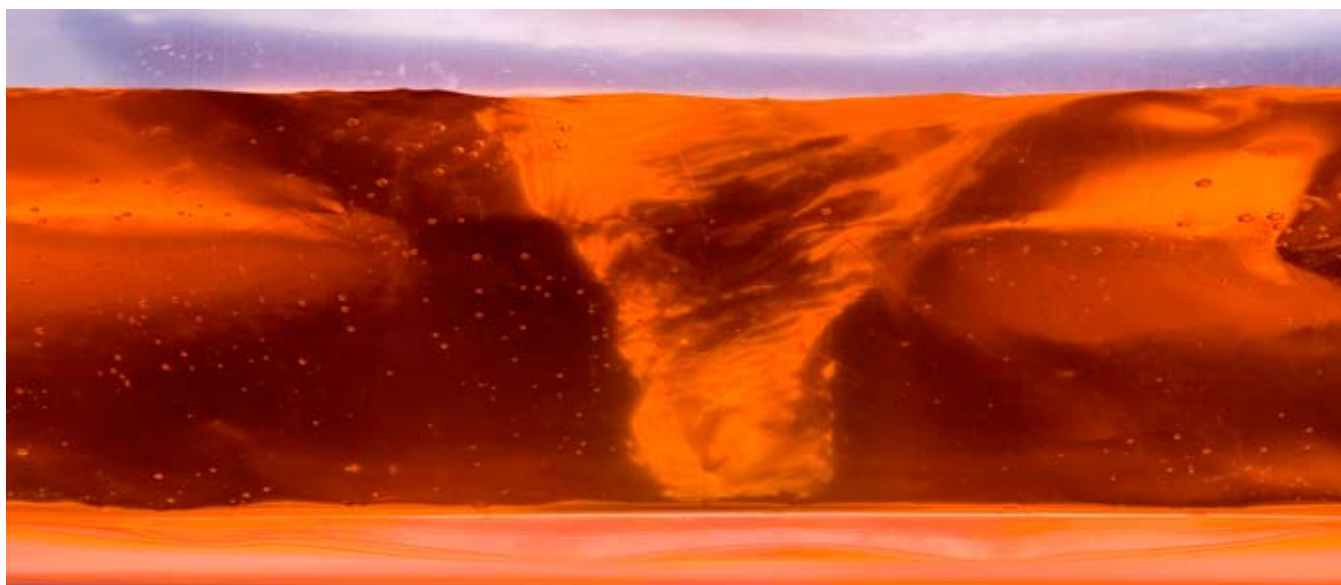

FREE FLOW® Valves

Pneumatically Actuated and Manual



Turbulence-Free Flow with Easy Cleaning and Fast Element Changes

Mitos Biotech’s FREE FLOW valves are designed specifically for the biotech industry. The straight-through bore eliminates turbulence to significantly reduce shear in the process line.

The patented FREE FLOW valve uses a smooth bored tubing element to convey media. Valve sealing anvils along with a compression bar control the flow from outside the tubing, never having contact with the media. The crevice-free flow path is conducive to easy and thorough cleaning, and the quick release hinge technology allows fast element changes without the use of tools.

Manually operated valves are easily actuated by rotating the hand wheel until snug. There is no need for tools. Pneumatically operated valves come ready to connect to an air supply. No field adjustments are necessary.



FREE FLOW Valve Features

- Quick release, tool-free element change out
- Easy to clean, seamless straight through flow path with no crevices to collect residue
- Three sizes: 1/2”, 3/4”, and 1”
- Valve element material options include: platinum-cured silicone, STA-PURE® PCS and STA-PURE® PFL tubing (Contact Mitos Biotech for size and material availability)
- Ideal for clamping tubing to isolate filters
- Steam-through capability



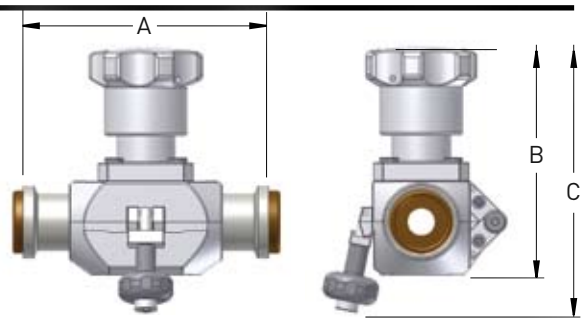
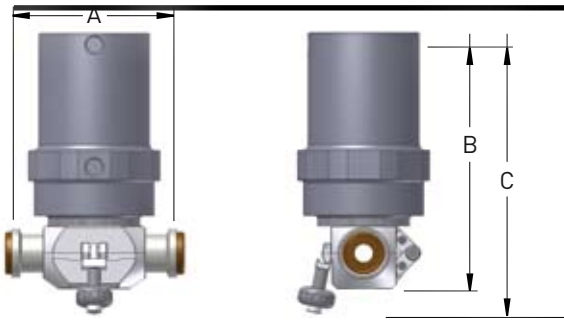

Pneumatically Actuated Valve Dimensions (1/8" NPT air inlet)			
Tube Element Size	A	B	C
1/2" (3/8" ID)	3.36	5.18	5.76
3/4" (5/8" ID)	3.90	5.80	6.45
1" (7/8" ID)	4.40	7.94	8.63

Manually Actuated Valve Dimensions			
Tube Element Size	A	B	C
1/2" (3/8" ID)	3.36	3.23	3.81
3/4" (5/8" ID)	3.90	4.07	4.72
1" (7/8" ID)	4.40	5.54	6.23

Materials of Construction

- Body - 304 stainless steel
- Valve Sealing Anvils - polyphenylene sulfide (PPS)
- Springs - 17-4PH stainless steel
- Fasteners - 18-8 stainless steel
- Seals - Nitrile and EPDM
- Stem Guides - PEEK
- Piston Stop - PVDF
- Lubricant - silicone gel

Note: 316 stainless steel is available by special order.



Materials of Construction

- Body - 304 stainless steel
- Valve Sealing Anvils - polyphenylene sulfide (PPS)
- Inserts - PEEK (standard, autoclave compatible)

Note: 316 stainless steel is available by special order.

Element Materials & Specifications

Tubing Material	Port Ends	Pressure Rating
Platinum-cured silicone	Tri-Clamp type, molecularly bonded, molded silicone ends with integrated gaskets, or 316L stainless steel crimp ends	45 psig line, 30 psig steam
STA-PURE PCS	Tri-Clamp type, molecularly bonded, molded silicone ends with integrated gaskets, or 316L stainless steel crimp ends	60 psig line, 40 psig steam
STA-PURE PFL (CHEM-SURE)	316 stainless steel crimp ends	60 psig line, 40 psig steam

Elements can be cleaned and sterilized by SIP/CIP and autoclave. Element materials are animal free and USP class VI approved.

Part Number Code

FFLQR - XX - XX - XXX - XX - X - XX

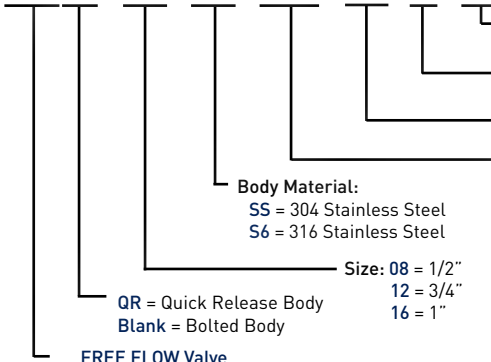

- Snugger ID:
10 = 5/8"
14 = 7/8"
20 = 1-1/4"
22 = 1-3/8"

- Snugger*(only used with continuous tubing elements):
Blank = No Snuggers
B = Both Snuggers
L = Left Snugger
R = Right Snugger

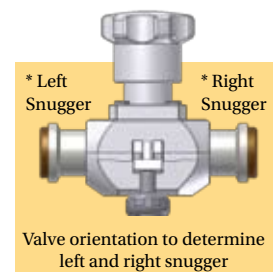

- Element Material:
Blank = No Element
SI = Silicone
SP = STA-PURE PCS
CS = STA-PURE PFL (CHEM-SURE)

Contact Mitos Biotech for material availability in specific sizes

Contact Mitos Biotech for high and low pressure options

Certification and Packaging

Each valve element is shipped in sealed virgin polyethylene with a label denoting part number, lot number, and description. A Certificate of Conformance is included with each shipment to certify that each element passes USP Class VI, cytotoxicity, physicochemical and visual inspection tests.



FREE FLOW Sampling Valves

Manually Actuated Parent and Child Valves

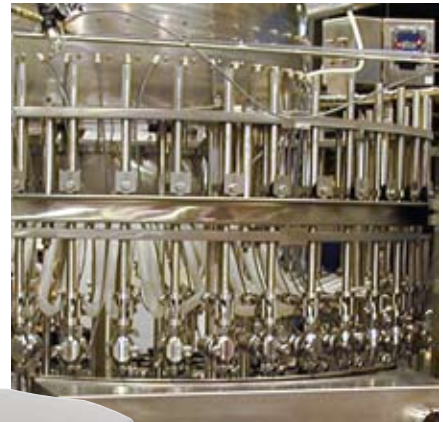

Multiple Ports with Smooth Flow Paths and Steam-Through Capability

Mitos Biotech's FREE FLOW Sampling Valves have a standard three port configuration consisting of manually actuated parent and child valves in a stainless steel housing.

The smooth bored tubing element is molded into a seamless T shape to convey media through the three ports. Valve sealing anvils along with compression bars control the flow from outside the tubing, never having contact with the media. Quick release hinge technology allows fast element changes without the use of tools.

Each port has a molded Tri-Clamp end with an integrated gasket to reduce sealing faces and potential contamination. Custom continuous tubing elements are also available.

Manually operated valves are easily actuated by rotating the hand wheel until snug. There is no need for tools. Pneumatically operated valves come ready to connect to an air supply. No field adjustments are necessary.



FREE FLOW Sampling Valve Features

- Quick release, tool-free element change out
- Easy to clean, seamless straight through flow path
- Valve element material is platinum-cured silicone
- Ideal for large volume sampling, additions, and block & bleed applications
- Completely drainable in any position
- Steam-through capability



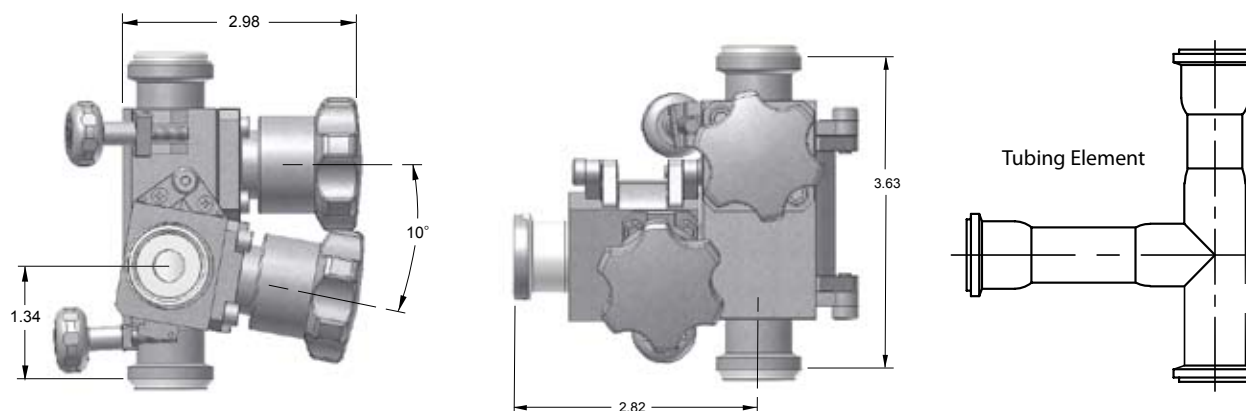

Materials of Construction		
	Size	Material
Tube Element	1/2" (3/8" ID)	USP Class VI platinum cured silicone tubing (animal free)
Body		Metal components are 304 stainless steel*
Valve Sealing Anvils		Polyphenylene Sulfide (PPS)

* 316 stainless steel bodies are available by special order.

Element Materials & Specifications		
Tubing Material	Port Ends	Pressure Rating
Platinum-cured silicone	Tri-Clamp type, molecularly bonded, molded silicone ends with integrated gaskets	45 psig line, 30 psig steam

Elements can be cleaned and sterilized by SIP/CIP and autoclave. Element materials are animal free and USP class VI approved.

The tube element material is molded into a T configuration providing a seamless fluid path with no areas of entrapment. Custom elements can be molded with a continuous leg for connection to tubing and bag systems.

Mitos Biotech's FREE FLOW Sampling Valves feature quick release hinge technology for fast element changes. It's as simple as, loosening the locking screws, unhinging the valve bodies, and removing the tubing element. Then all product contact surfaces can be disposed without the need for cleaning or sanitizing the stainless steel parts.



Part Number Code

FFLQR2P - 08 - SS - SAM - XX

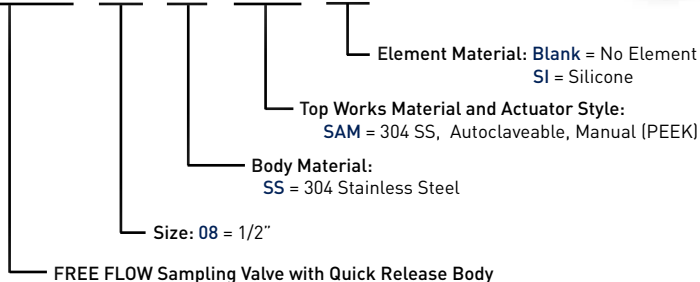

Certification and Packaging
 Each valve element is shipped in sealed virgin polyethylene with a label denoting part number, lot number, and description. A Certificate of Conformance is included with each shipment to certify that each element passes USP Class VI, cytotoxicity, physicochemical and visual inspection tests.

DuraPure™ Bioprocess Bag Systems



Mitos Biotech has expanded its DuraPure Bioprocess Bag line to an integrated fluid-handling system designed for durability and purity. When creating a DuraPure Bioprocess Bag System with our customers, we not only consider the bag, but every component that surrounds it (storage vessels, tubing, molded junctions, sanitary fittings, peristaltic pumps, filters and valves). Each system is designed to seamlessly integrate with the rest of your process, whether it is going from media prep to cell culture, or ultrafiltration to final fill.

Versatility

- DuraPure Bags are available in the following sizes: 250mL, 1L, 5L, 10L, 20L, 50L, 100L, 500L, 1000L.
- mitos-P, mitos-C platinum-cured tubing with molded junctions and sanitary fittings
- TPE tubing with molded junctions and sanitary fittings
- Plastic & stainless steel storage vessels

Purity

- USP Class VI testing
- LAL testing
- Systemic toxicity testing
- Intracutaneous reactivity testing
- Muscle implantation testing
- cGMP manufacturing



Systems Integration

- Peristaltic Pumps
- Filters
- Valves
- Sampling Systems

mitos-P



mitos-P is a nonreinforced platinum-cured silicone tubing with lot and part number etched directly onto the tubing. This precision tubing is manufactured with an automated control system that repeatedly measures the inner bore and wall thickness maintaining a 0.002" to 0.008" tolerance. mitos-P is well suited for performance in applications requiring use of peristaltic pumps and/or molded assemblies

Fittings

- Molded Tri-Clamp
- Radially-Crimped 316 Stainless Steel
- All other industry standard connections

Applications

- Peristaltic Pumps
- Manifold Assemblies
- Bulk Tubing
- Bag Systems
- Low Pressure Transfer Lines
- Single-Use Applications

Features

- Lot number, tube ID and wall thickness marked on each tube
- Tightest wall tolerance available (0.002" to 0.008")
- Ideal for molding with other silicones into manifold assemblies (Ts, Ys, crosses, elbows and reducers)
- Certificate of Conformance included with each order
- Manufactured in Class J (10,000) clean room with raw materials kept at a constant temperature and humidity to maximize extrusion characteristics
- Can be chemically or mechanically cleaned and can be sterilized by chemicals, autoclave or gamma-irradiation
- Shore hardness of 60 +/- 5 Shore A
- Available in four different wall thicknesses and internal diameters up to 1"

Ideal for Use in Peristaltic Pumps & Molded Assemblies

mitos-P is the preferred platinum-cured silicone tubing for use in peristaltic pumps and molded assemblies because of its consistency in dimensions. This consistency delivers optimum performance in both applications by providing steady flow rates during pumping and by ensuring better bonding during molding, giving greater integrity to the assembly.



mitos-C



mitos-C is a non-reinforced platinum-cured silicone tubing that is suitable for most biotech applications.

Fittings

- Molded Tri-Clamp
- Radially-Crimped 316 Stainless Steel
- All other industry standard connections

Applications

- Manifold Assemblies
- Bulk Tubing
- Bag Systems
- Low Pressure Transfer Lines
- Single-Use Applications

Features

- Can be molded with other silicones into manifold assemblies (Ts, Ys, crosses, elbows and reducers)
- Certificate of Conformance included with each order
- Manufactured in a clean environment
- Can be chemically or mechanically cleaned and can be sterilized by chemicals, autoclave or gamma-irradiation
- Shore hardness of 50 +/- 5 Shore A
- Available in six different wall thicknesses and internal diameters up to 1"

mitos-R

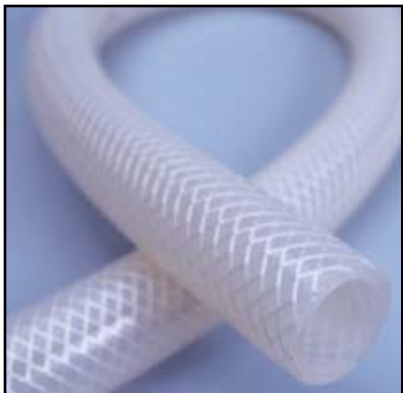

mitos-R is a platinum-cured silicone hose with fiber braid reinforcement structure to maintain flexibility, withstand high pressure and resist kinking.

Fittings

- Molded Tri-Clamp
- Radially-Crimped 316 Stainless Steel
- All other industry standard connections

Applications

- Manifold Assemblies
- Bulk Tubing
- High Pressure Transfer Lines
- Single-Use Applications

Features

- Lot number available with CLEAR-mark label
- Certificate of Conformance included with each order
- Can be molded with other silicones into manifold assemblies (Ts, Ys, crosses, elbows and reducers)
- Manufactured in a clean environment
- Can be chemically or mechanically cleaned and can be sterilized by chemicals, autoclave or gamma-irradiation
- SIP/CIP capable
- Available with internal diameter up to 1"



STA-PURE® PCS Series Peristaltic Pump Tubing

Manufactured by W.L. Gore, this platinum-cured silicone tubing is reinforced with Teflon® to provide extra strength to prevent premature rupture, yield stable flow rates and eliminate tube particulate shedding, even after thousands of hours of peristaltic pumping. Its superior life and pressure characteristics make STA-PURE PCS tubing ideal for the manufacturing stages at which your product is most valuable.



Fittings

- Molded Tri-Clamp
- Radially-Crimped 316 Stainless Steel
- All other industry standard connections

Applications

- Peristaltic Pumps
- Mitos Biotech FREE FLOW Valve
- Tangential Flow Filtration
- High Pressure Pumping
- Tablet Coating
- Perfusion Reactors
- Final Fill and Finish
- Metering and Dispensing

Features

- Smooth inner bore
- Platinum-cured silicone surface contact
- Stable flow rate
- Lasts 18 times longer than silicone
- No spallation (particulation from tubing)
- Certificate of Conformance included with each order
- FDA Type II Material Master File available for citation
- Manufactured in a Clean Concepts Environment
- Can be chemically or mechanically cleaned and can be sterilized by chemicals or autoclave
- CIP/SIP capable



Proven Fitting System for STA-PURE PCS Series Tubing

Mitos Biotech offers the only fittings system specially designed for STA-PURE PCS Series tubing. Mitos Biotech worked side by side with W.L. Gore to create the only system that is fully validated for steam pressure and can withstand repeated CIP/SIP. While other fittings can cut the tubing, Mitos Biotech's fittings maintain their integrity to provide optimal performance of the tubing assembly.



mitos-W is a platinum-cured silicone hose with multi-ply fiber braids and 316 stainless steel helical wire reinforcement for high pressure or vacuum applications.

Fittings

- Molded Tri-Clamp
- Radially-Crimped 316 Stainless Steel
- All other industry standard connections

Features

- Lot number available with CLEAR-mark label
- Certificate of Conformance included with each order
- Smooth inner bore
- Manufactured in a clean environment
- Can be chemically or mechanically cleaned and can be sterilized by chemicals, autoclave or gamma-irradiation
- SIP/CIP capable
- Available with internal diameter up to 3"



mitos-WCO is a platinum-cured silicone hose with multi-ply fiber braids, 316 stainless steel helical wire reinforcement and a convoluted exterior. The convoluted exterior provides unsurpassed bend radius and resistance to kinking.

Fittings

- Molded Tri-Clamp
- Radially-Crimped 316 Stainless Steel
- All other industry standard connections

Features

- Lot number available with CLEAR-mark label
- Certificate of Conformance included with each order
- Smooth inner bore
- Manufactured in a clean environment
- Can be chemically or mechanically cleaned and can be sterilized by chemicals, autoclave or gamma-irradiation
- SIP/CIP capable
- Available with internal diameter up to 4"

Applications

- Hose Assemblies
- Bulk Transfer Lines
- High Pressure Systems
- Vacuum Applications
- SIP/CIP Carts
- Load Cells

mitos-W



mitos-WCO



Teflon Hose

mitos-TRC



mitos-TRC hose has a smooth Teflon fluoropolymer inner bore and durable rubber cover. With its unmatched chemical resistance and purity, mitos-TRC is a true utilitarian hose that can be used anywhere in the plant.



Fittings

- Radially-Crimped 316 Stainless Steel
- All other industry standard connections

Applications

- Pharmaceutical & Food Processing
- SIP/CIP Delivery Systems
- WFI (Water For Injection)
- Bulk Transfer

Features

- Smooth Teflon fluoropolymer inner bore with durable rubber cover
- Unsurpassed chemical compatibility
- Virtually zero TOC
- Durable, kink resistant
- Certificate of Conformance included with each order
- Autoclave, SIP/CIP and vacuum capable
- Available with internal diameter up to 4"

mitos-SBF



mitos-SBF utilizes a smoothbore PFA tube, a bonded, wire braid - silicone - textile braided composite, giving this product a superior bend radius, kink and vacuum resistance. This proprietary tube technology can then be additionally reinforced with any application specific braid for working pressure and abrasion resistance.



Fittings

- Radially-Crimped 316 Stainless Steel
- All other industry standard connections

Applications

- Aggressive Chemical Handling
- Pharmaceutical & Food Processing
- SIP/CIP Delivery Systems
- WFI
- Bulk Transfer

Features

- All purpose
- Corrosion resistant
- High and low temperature capability
- Non-contaminating
- Economical

Molded Silicone Manifolds

With custom-designed manifolds, Mitos Biotech Business Unit molds imagination into reality. Whether a foot-long piece of tubing with sanitary ends or a manifold with over 100 junctions, Mitos Biotech can mold single- or multi-use systems tailored to your application. Our proprietary technology allows for any configuration of Ys, Ts, crosses, reducers and elbows, with unlimited lengths between molds.

Each mold is molecularly bonded to the tubing by cross-linking of the elastomer chains. This permanent connection prevents product loss and contamination commonly experienced with hose barb failures. Internally, molds are seamless and crevice-free to eliminate entrapment areas and potential contamination.

Molded manifolds can be created out of mitos-P, mitos-C, mitos-R, STA-PURE PCS tubing, or a combination of styles. Mitos Biotech molded manifolds are fully validated and delivered with a Certificate of Conformance.



Y Mold

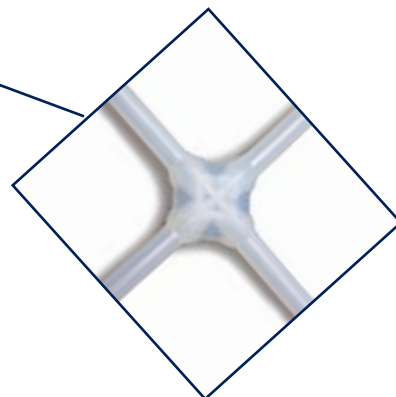

Cross Mold

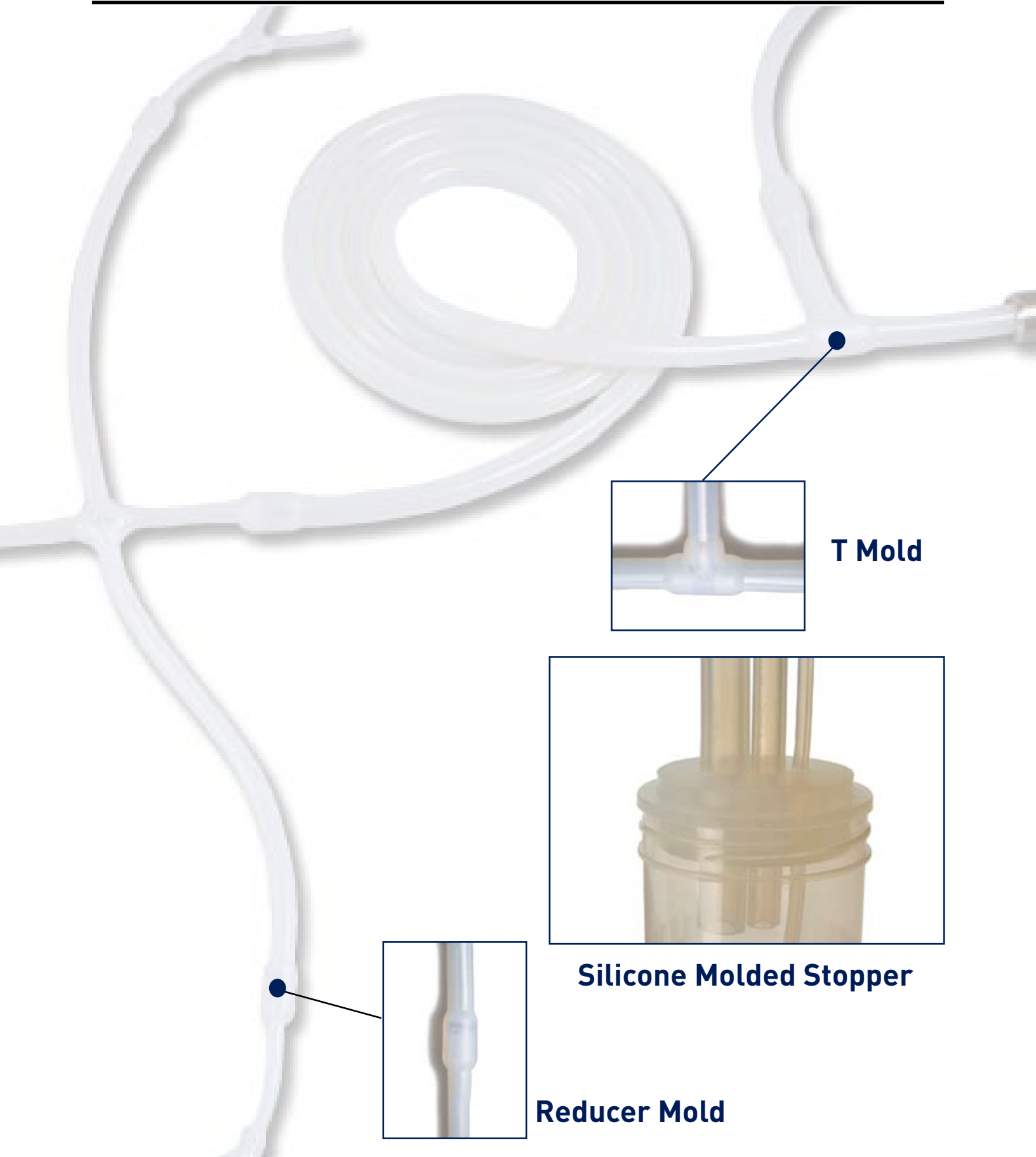

T Mold



Silicone Molded Stopper



Reducer Mold

Fittings

Molded Silicone

Molded silicone fittings are the ideal option when you there is a need for an easily cleanable assembly, or to reduce the risk of cross-contamination. In each Mitos Biotech molded fitting, the elastomer chains of the platinum-cured silicone are cross-linked to create a permanent molecular bond to the tubing. A special feature of our molded Tri-Clamp is an integrated gasket that, when connected to another fitting, eliminates 50% of the sealing faces creating seamless and crevice-free fittings. Molded silicone fittings are available on mitos-P, mitos-C, mitos-R and STA-PURE PCS tubing.



For extra support, Mitos Biotech offers a full stainless steel or plastic backup cup on the outside of each molded fitting. Our plastic back-up cups have a unique wraparound design that fully encases the Tri-Clamp mold, making them impossible to pull off.

Radially-Crimped Stainless Steel

Mitos Biotech offers a comprehensive line of industry standard connection options. All Mitos Biotech stainless steel fittings are 316 stainless steel and are available in an electropolished or standard machine finish. Our stainless steel fittings are manufactured in a U.S. based facility dedicated exclusively to fabricating sanitary fittings for the biotech industry. Because Mitos Biotech fittings come from a single source, components are unparalleled in material consistency, dimensions, surface finish and craftsmanship. All fittings feature a heat identifier which allow them to be fully traceable.



Connectors



Mitos Biotech utilizes all connector options that are required for use by the biotech industry. We provide a full line of connectors from an array of manufacturers that are all compatible with Mitos Biotech components and systems. With every different type of connector option available, it is our goal to be able to provide our customers with one-stop-shop convenience to meet all connection needs.

Connector Offering Includes

- Parker
- Pall
- Millipore
- CPC
- GE
- SciLog Sensors



Stainless Steel Components



Mitos Biotech offers a variety of stainless steel fittings including hose barbs, mono barbs, tube by pipe, thread adaptors and shortened reducers. To ensure the highest quality, all stainless steel components are manufactured in the U.S.A. in a facility dedicated exclusively to fabricating sanitary fittings for the biotech industry. All components are laser engraved with heat numbers to provide full traceability.



Features & Benefits

- 316 stainless steel
- Mill Test Results (MTR) with each order
- Heat number laser engraved for traceability
- 15 Ra or better electropolish finish standard on all internal surfaces
- Hose barbs tapered for greater flow and to prevent moisture entrapment
- Gauge reducers have a maximum overall length of 1.75"

mitos i-cap™



The mitos i-cap is a patented design that makes removal of end caps easier and safer for both the user and equipment. The i-cap's unique I shape fits into the pronged end of any standard Tri-Clamp clamp. Just hook the clamp onto the i-cap and it pops off easily without risk of injury or damage to the end cap face or attached equipment. Each i-cap is made of electropolished 316 stainless steel and features a heat traceable identifier.

Features

- Safe, ergonomic design
- Special pop off knob fits into industry standard clamps
- 316 stainless steel construction
- Heat traceable identifier



Size (inch) Available
.5 & .75
1.0 & 1.5
2.0
2.5
3.0
4.0
6.0

Benefits

- Easy removal without use of dangerous methods (eg, screwdrivers)
- No damage to end cap or equipment during removal
- Prevents user injury



Note: mitos i-cap prevents damage and offers a safe alternative to dangerous methods of removal



i-logic™ gasket systems



The i-logic gasket system offers smooth-bore sealed connections with color-coded and lot-numbered gaskets for rapid process identification. This system includes the i-logic gasket, i-Torquer™ wrench and slotted clamp.

Made of platinum-cured silicone or EPDM, the i-logic gasket is designed specifically for use with sanitary Tri-Clamp fittings. Unlike other gaskets that extrude into the ID of the fitting when tightened, the i-logic gasket creates a smooth seal on the inner bore of the connection. A smooth-bore sealed connection allows for proper drainage, prevents deterioration of exposed gasket materials and provides unobstructed flow to shear-sensitive products.



The companion i-Torquer wrench delivers consistent radial force to the flange assembly to eliminate over or under-tightening. The entire i-logic system matches present technologies, making it compatible with any sanitary fitting.

Features

- Smooth-bore sealed connection
- Color coded (clear, white, pink, red)
- Lot traceable
- Certificate of Compliance (biocompatibility testing and lot number)

Benefits

- Nonparticulating
- Gaskets resist chemical reversion from high-temperature steam
- No overextrusion of gasket into process stream
- Better drainage
- Color coding and lot traceability provide fast and easy process identification and traceability

CLEAR-mark™

CLEAR-mark Label



Developed by Integra Companies, Inc., CLEAR-mark silicone hose labels are permanently bonded to the hose without creating entrapment areas and crevices. CLEAR-mark labels are durable and suitable for repeated autoclave and steam in place/clean in place (SIP/CIP) cycles. As label application is part of hose fabrication, quick turn-around time is never sacrificed.

Features

- Permanently bonded to hose
- Marked with easy-to-read customer, hose, and manufacturer information
- Available in the following colors: clear, black, gray, red, orange, yellow, blue, green, purple, brown
- Zero entrapment areas & easy to clean
- Suitable for SIP/CIP, autoclave and gamma-irradiation

Benefits

- Will not rub, peel or fall off
- No media contact
- Easily identified, customized information
- Fast turn-around
- Part number on hose ensures accurate reordering

Engineering Your Success - PERFECTFIT™



When it comes to tubing and hose assemblies, Mitos Biotech follows the "measure twice, cut once" principle. This led us to create PERFECTFIT, an elective service available to customers with the purchase of any new tubing or hose assembly. Once you have decided on the right product, Mitos Biotech will send a qualified technician to your site to measure specific hose length requirements. This complimentary step in the buying process ensures that your exact specifications are met, making your assembly a PERFECTFIT every time.



Assembly & Gamma Services

Assembly Services

Many of our customers find constructing their own assemblies too time consuming and labor intensive. To decrease these costs and simplify the manufacturing process, Mitos Biotech offers assembly services. Our sales team will work with you to understand the exact needs of your assembly, competitively price components and labor, and then coordinate with our CAD designers to provide a detailed drawing of the finished assembly.

Each assembly is constructed in a controlled environment, individually heat sealed in all-virgin polyethylene bags and shipped with a Certificate of Conformance. Depending on materials used, Mitos Biotech can have finished assemblies sterilized by gamma irradiation. Let Mitos Biotech provide your assemblies so you can concentrate resources where they will be most effective.

Gamma Irradiation Services

Increasingly our customers are finding it easier and more cost-effective to have Mitos Biotech products pre-sterilized by gamma irradiation. The convenience of sterile, ready-to-use assemblies dramatically reduces cleaning and validation time and costs.



Mitos Biotech products are irradiated in individual carriers to prevent contact with, or proximity to unidentified and unlike products. During the standard exposure time, the carrier undergoes irradiation on both sides for an even exposure to gamma rays. Unlike other providers, each box of our gamma-irradiated products is marked with multiple dosimeters to give a specific, more accurate dose reading with every run. All dosimeters feature a bar code for traceability of all irradiation parameters and can be reread years later with validatable results.

Each gamma-irradiated product is double-bagged and shipped with a Certificate of Irradiation and a "gamma dot" showing that the product has been exposed to gamma rays.

Biotechnology:

Biotechnology refers to methods and techniques that involve the use of living organisms, such as cells, bacteria, yeast, as tools to perform specific tasks or functions in industry including Life Sciences. Biotechnology is typically used to make useful products or materials.

Biopharmaceutical:

Biopharmaceuticals are a subset or sister of traditional pharmaceuticals and refers to drugs manufactured using biotechnology. These drugs have biological/living sources usually involving live organisms or their active compounds. The products are therefore “grown” and subsequently “harvested”. Recombinant proteins, monoclonal antibodies, vaccines and other blood derived products can all be referred to as biopharmaceuticals. Biopharmaceuticals are typically administered via injection.

Single-Use Products:

Biopharmaceutical products were traditionally manufactured in stainless steel bioreactors and related processing equipment. This equipment required costly and time consuming cleaning and sterilization steps between each batch. Many biopharmaceuticals are now manufactured in “single-use” systems where wetted surfaces are replaced after each use. The incorporation of single-use systems have many benefits over traditional manufacturing processes:



- Reduced chance of batch-to-batch cross contamination
- Faster set-up of new systems and batch-to-batch change over
- Reduced capital equipment cost and time to construct new manufacturing capability
- Reduced cost for Clean In Place (CIP) and Steam In Place (SIP) processes and related infrastructure
- Increased facility flexibility to run multiple products or scale up/down production capacity

