

316L Stainless Steel Explosion Proof Coil for Oil and Gas Market

Lucifer® ATEX "d" Coil
Ref. 497105



Product

The new 316L Stainless Steel Explosion Proof Flameproof "d" Coil Ref. 497105 is valid for Zone 1/21 and is compatible with existing Parker Lucifer Valve X, V, and F Series.

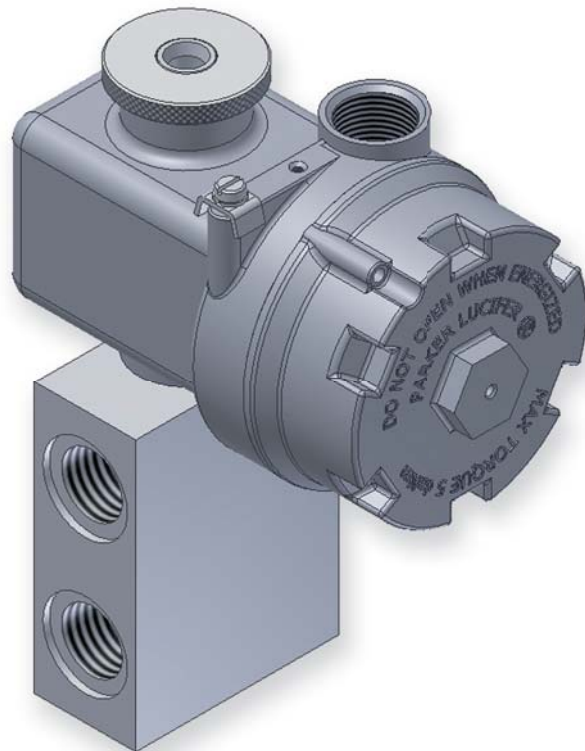

Contact Information

**Parker Hannifin Manufacturing
Switzerland SA**

Fluid Control Division Europe

Ch. Fbg de Cruseilles, 16
1227 Carouge / Genève
Switzerland

Tel.: +41 22 30 77 111

Fax: +41 22 30 77 110

www.parker.com/fcde

Markets

- Chemical
- Petrochemical
- Oil & Gas industries

Applications

Control of solenoid valves in hazardous areas Zone 1-21

Benefits

- Light and compact design
- Highly resistant to corrosion
- Easy mounting and dismounting
- Easy maintenance
- Modular with all other current ATEX Parker Lucifer coils
- Inventory reduction for distributors
- The coil can be assembled or disassembled from its valve very easily
- Quick electrical cable connection
- The coil permits reversible up or down position of the threaded 1/2" NPT cable entry with 360° rotation capability



ENGINEERING YOUR SUCCESS.

Technical Data

- All metallic housing is made of full 316L stainless steel.
- Low Power consumption 8W Max
- 1/2" NPT cable entry
- Protection level IP 66
- Peak voltage suppression and AC rectification included as standard

ATEX "d" Coil Ref. 497105 is compatible with existing Parker Lucifer Valve X, V, and F Series.



ATEX "d" Coil Ref. 497105 is modular with all other current ATEX Parker Lucifer coils.

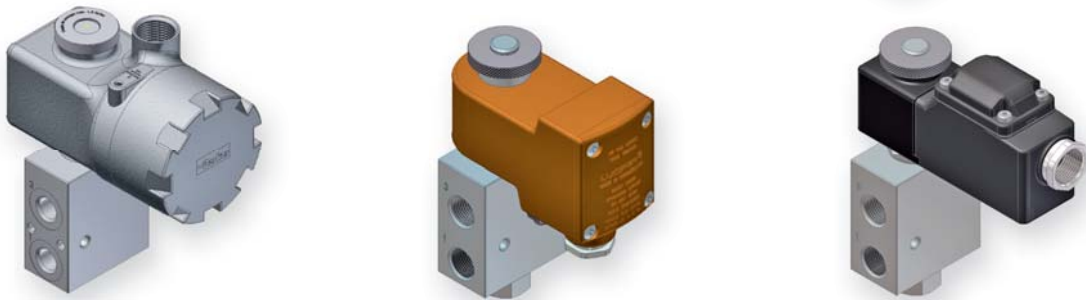

Dimensions

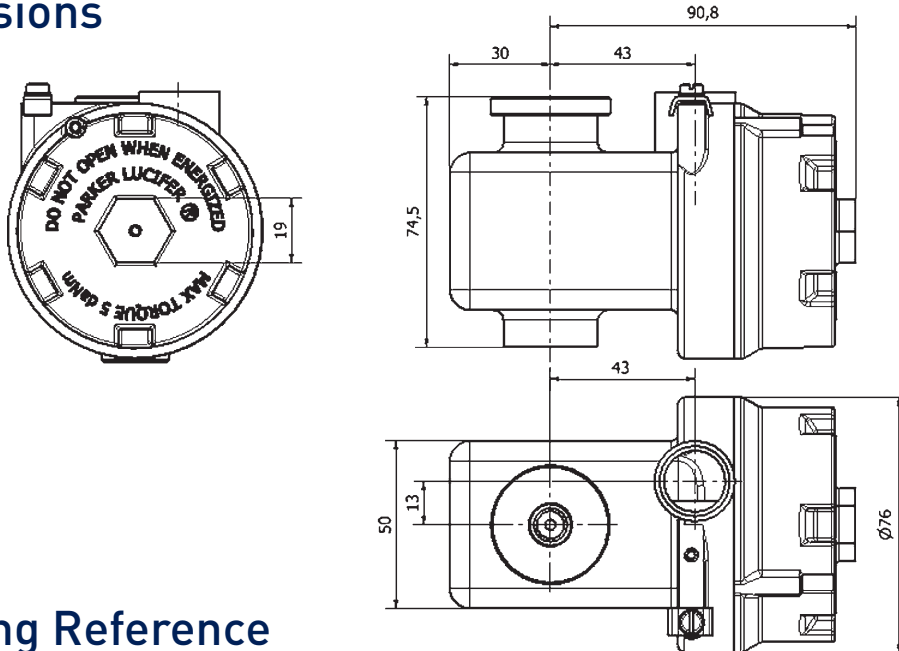

Ordering Reference

ATEX "d" Coil Ref. 497105 + Voltage Code



EMEA Product Information Centre

Free phone: 00 800 27 27 5374

(from AT, BE, CH, CZ, DE, DK, EE, ES, FI, FR, IE, IL, IS, IT, LU, MT, NL, NO, PL, PT, RU, SE, SK, UK, ZA)

US Product Information Centre

Toll-free number: 1-800-27 27 537

www.parker.com