

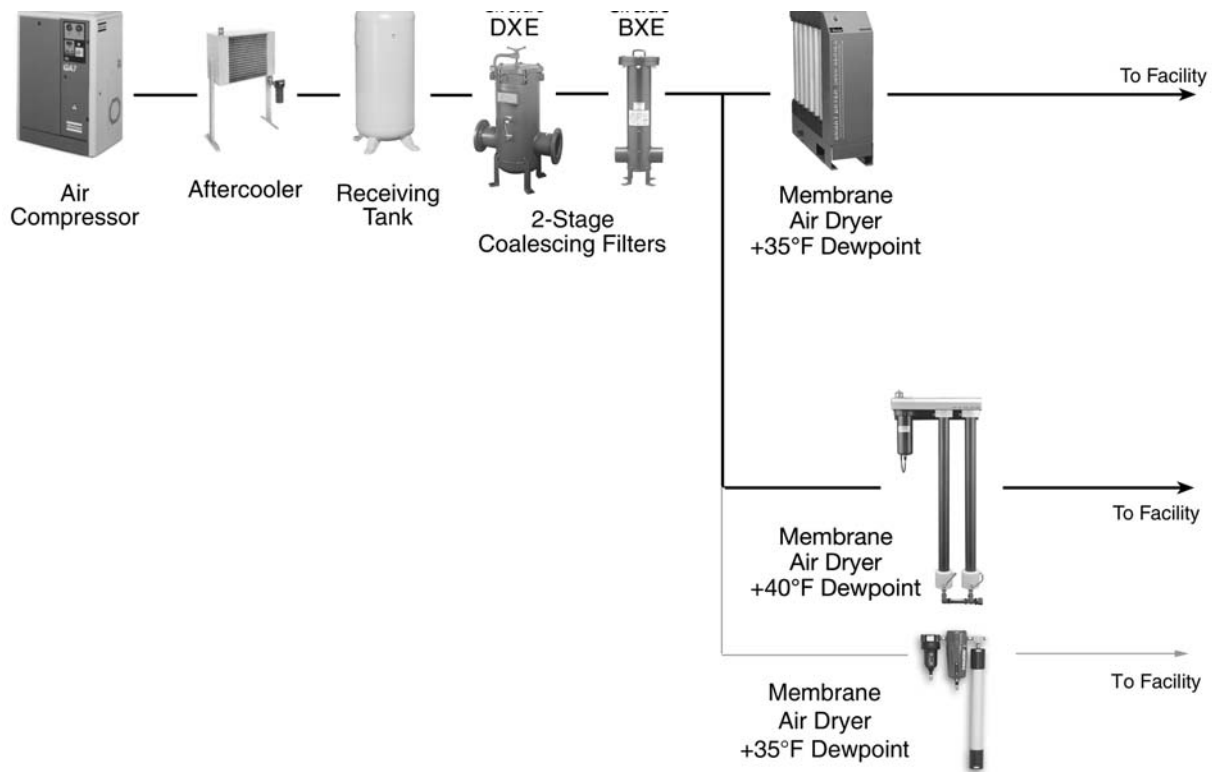

# Drying Compressed Air

Bulletin M261H

## Optimum Compressed Air System



## 1 Introduction

Any user of compressed air will, at some point, see liquid water appearing in the air distribution system. This can be anything from a nuisance to a serious problem, depending on the application. Getting the water out of the compressed air depends on understanding where it came from and what methods are available to remove it. Any liquid or vapor removal process, such as drying the air, costs money. Therefore, it is important to clearly define the result required and specify the right equipment in order to find the most economical solution to the water problem.

## 2 Where does the water come from?

Water is present in the air which is drawn into the compressor. The water is gaseous – invisible and completely mixed with the air. The exact amount of water is called the “humidity” of the air.

- a) **Relative Humidity-** The amount of water vapor that can be held in air is dictated by the temperature of the air. Hot air can hold more water (as vapor) than cold air. Typically, atmospheric air contains approximately 50% of its water vapor holding capacity for a given temperature. This proportion of the maximum vapor holding capacity is referred to as **relative humidity**.
- b) **Dewpoint and Condensation-** When air with a given relative humidity is cooled, it reaches a temperature at which it is saturated. At saturation, the relative humidity of the air is 100%, i.e., the air contains as much water vapor as it can hold. The temperature at which the air is at 100% relative humidity is known as the **dewpoint** of the air. Cooling air beyond the dewpoint results in **condensation** of the water vapor.
- c) **Cooling and Condensation in Compressed Air-** The table below details the changes in 8 cubic feet of air as it is compressed to 100 psig and subsequently cooled in an aftercooler. Worthy of note is the effect of the air temperature rise as the air is compressed. The increased temperature of the compressed air increases its vapor holding capacity which, in turn, reduces the relative humidity of the air because the actual water vapor content (74g) has remained constant. We must also note, however, that compressing the air has also increased the dewpoint of the air. This means that subsequent cooling of the air (by an aftercooler or as a result of a cooler ambient temperature) could cause condensation. Using an aftercooler, as shown, can remove a significant proportion of the water vapor (75%, as shown in the table) from the air through the principal of condensation. When leaving the aftercooler, the compressed air is saturated-any further cooling of the air will result in condensation. It is this cooling beyond the dewpoint of the compressed air which causes the water which end users see in their compressed air supplies.

**Table 1  
Compressing Air**

	INTAKE	OUTLET	AFTERCOOLER
Volume	8 cu.ft.	1 cu.ft.	1 cu.ft.
Pressure (gauge)	0 psig	100 psig	100 psig
Temperature (example)	68°F (20°C)	158°F (70°C)	68°F (20°C)
Water Content (vapor)	2.1g	2.1g	0.6g
Relative Humidity	50%	30%	100%
Dew Point (at pressure shown)	50°F (10°C)	97°F (36°C)	68°F (20°C)

**d) Sources of Cooling** – There are many ways to cool saturated compressed air :

- Ambient Conditions - Expose compressed air lines to cooler outdoor temperatures
- Expose compressed air lines to unheated rooms
- Pressure Reduction - Pressure regulators, vortex tubes, expansion vessels, and receiving tanks
- Process Equipment - Aftercoolers, dryers

### 3 Getting The Water Out

Usually, compressed air contains water in both the liquid and vapor phases. “Drying” means removing water, ranging from trapping the condensed water to preventing additional condensation of water vapor to removing virtually all the water present. The more water removed, the higher the cost of drying. However, if too much water is permitted to remain in the compressed air supply, the price is paid in maintenance costs, corrosion, and/or product losses. These costs, outright as well as hidden, support the importance of specifying the proper drying technology for a given application.

### 4 Drying Methods Available

The following list is a summary of the drying technologies available:

- Aftercooler - Reduces the temperature and water content of the compressed air.
- Water Traps - Remove bulk water condensed by the aftercooler.
- Coalescing Filters - Remove aerosol water and other liquids which bypass the water traps.
- Pressure Reduction - Drying through expansion.
- Refrigeration - Drying to dewpoints of approximately 37°F (3°C)
- Chemical Dryers - Reduces dewpoint by about 50°F (10°C)
- Desiccant Dryers - Drying to dewpoints of approximately -40°F to -100°F (-40°C to -73°C)
- Membrane Dryers - Variable drying capabilities to approximately -40°F (-40°C) dewpoint

An efficient aftercooler is essential to all compressed air systems and will condense up to 75% of the water vapor, as seen earlier. For example, if air enters a 3500 scfh compressor at 68°F (20°C) and exits at 100 psig and 248°F (120°C), it will release about 13 gallons (67 liters) of condensed water per day into the air distribution system while cooling down to 68°F (20°C). In the absence of an aftercooler, installing coalescing filters at various points in the system will remove much of the condensate, but if the air temperature at any filter is higher than room temperature, water will condense downstream from the filter as soon as the air cools a few more degrees. The only way to prevent condensation of the water throughout the system is to install an efficient aftercooler immediately after the compressor, and an efficient coalescing filtration system (with automatic drains) downstream from the aftercooler. Water may still condense downstream from the filter if the aftercooler has not reduced the air temperature to room temperature, but this relatively small quantity of condensate can be eliminated by the simple technique described in section 5.2, Pressure Reduction.

## 5 Drying Methods – Capabilities

### 5.1 Coalescing Filters

Coalescing filters are essential to remove compressor lubricant, water droplets and particles from the compressed air supply. Coalescing filters remove only liquids and particulate (not vapors) from a compressed gas stream. A moderately efficient coalescing filter should be used to remove the water condensed in the aftercooler. The addition of a high efficiency coalescing filter (Balston® Grade BX-99.99% removal of 0.1 micron droplets and particulate) at the point where the air is used ensures that any liquid condensed in the distribution system will be removed, as long as no further cooling occurs. The compressed air delivered after coalescing filtration will be free of liquids, but could be relatively high in water vapor content.

### Filter Locations

#### At the Compressor

The standard compressor installation consists of a compressor, a water-chilled aftercooler, and a receiver. A Balston coalescing filter should be installed downstream from the receiver. In a system with an efficient aftercooler, the distance from the receiver to the filter is not important. Since the filter is usually maintained by the personnel responsible for the compressor, it is often convenient to install the filter immediately after the receiver. Filter specifications are:

- Microfibre® Filter Cartridge – Balston Grade DXE
- Filter Housings – sized from flow chart, but port size **must** be equal to or larger than the line size
- Automatic Drain – required
- Differential Pressure Indicator – recommended for line sizes 1" and larger.

Some compressor installations do not have an aftercooler, this is **not** a recommended situation. Air saturated with water vapor leaves the compressor at temperatures between 230°F and 392°F (110°C and 200°C) and cools to approach room temperature in the distribution lines. Although water will condense throughout the air distribution system, about two-thirds of the total water content of the air will be condensed when the air has cooled to 104°F (40°C). Therefore, to remove most of the water load from the system a mainline filter must be installed just prior to the first distribution line manifold. However, since the air will continue to cool in the distribution system, additional filters located at end-use points will be required to remove water condensed downstream from the main line filter.

Figure 1

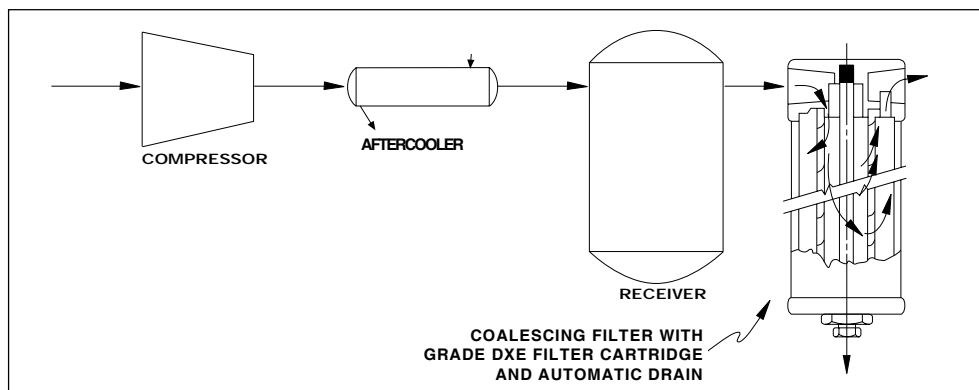

**At the Point of Use**

If instrument quality air is required at end-use points it is recommended that a Balston Grade BXE filter is installed, even if a main line Balston Grade DXE filter has been used upstream. These point-of-use filters will remove dirt and oil which may have been in the distribution lines, as well as water which has condensed downstream from the main filter. If there is a pressure regulator at the end-use point, the filter should be installed immediately upstream from the regulator. Alternatively, a Balston Filter Regulator assembly could be installed to replace the existing regulator.

For applications requiring relatively clean air, such as pneumatic instruments, the recommendations for the final filter are:

- Microfibre Filter Cartridge – Balston Grade DXE
- Filter Housings – sized from flow chart, but port size **must** be equal to or larger than the line size
- Automatic Drain – required

If there is no Grade DXE filter upstream from the final filter, or if a significant amount of water or oil is expected, then a two stage system, Grade DXE followed by Grade BXE, is required at each use point. The housing and automatic drain for the Grade DXE prefilter should be the same as for the Grade BXE final filter.

Even if the end-use application is not particularly sensitive to impurities in the air – for example, an air-driven tool – it is still good practice to filter at the end of the line, to remove condensed water and reduce maintenance costs and eliminate unanticipated downtime. A single stage Balston Grade DXE filter with an automatic drain is recommended.

Figure 2

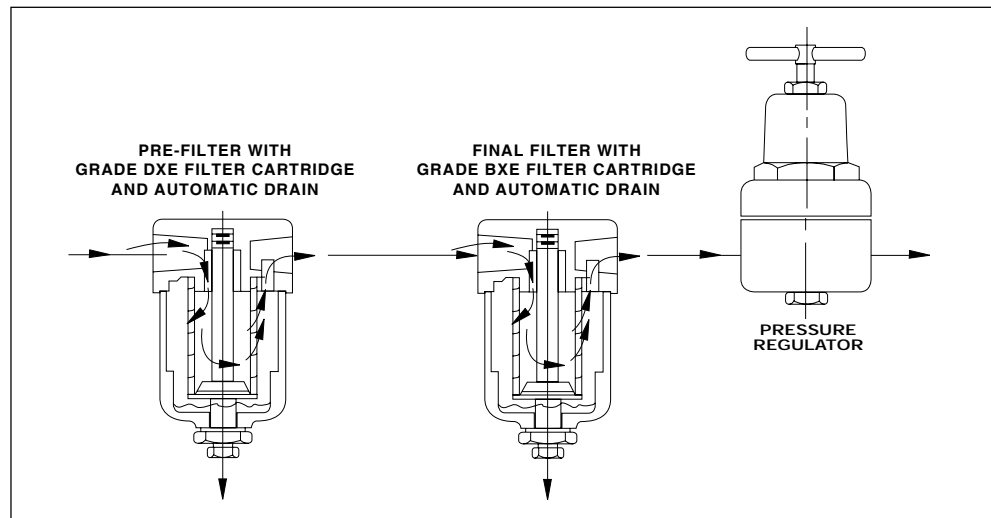

**5.2 Pressure Reduction**

In air distribution systems not subject to freezing temperatures, the function of the filter is to prevent condensed water from entering the air-operated equipment. This application requires care in selecting the filter and in positioning it correctly on the air line.

Virtually all air supplies are regulated from a higher line pressure to a lower line pressure at the use point. As such, it is possible to take advantage of the “drying” effect of pressure reduction. Air at lower pressures holds more water vapor than air at higher pressures (at the same temperature). Therefore, less water vapor will condense out of the air at the reduced pressure. For example, Table 2 shows the drying effect of reducing the pressure of air saturated with water from 90 psig (6 bar) to 45 psig (3 bar) at 68°F (20°C).

(Note: In air systems with small line sizes and low flows, the air downstream from the pressure regulator will cool slightly after expansion, and quickly warm to room temperature.)

Table 2

THE DRYING EFFECT OF REDUCING PRESSURE		
	Air In	Air Out
Pressure	90 psig (6 bar)	45 psig (3 bar)
Temperature	68°F (20°C)	68°F (20°C)
Dew Point	68°F (20°C)	52°F (11°C)

If the air is subject to freezing temperatures or is used in an application that water vapor in the air can be harmful to the process, a dryer is required.

**Preventing Water Condensation**

In order for pressure reduction to have the drying effect illustrated in the above table, there must be no condensed water present in the air entering the pressure regulator. If liquid water enters the regulator, it will evaporate when the pressure is reduced, and the air leaving the regulator would then have a 68°F (20°C) dewpoint. Thus, any cooling downstream would cause further condensation.

Figure 3

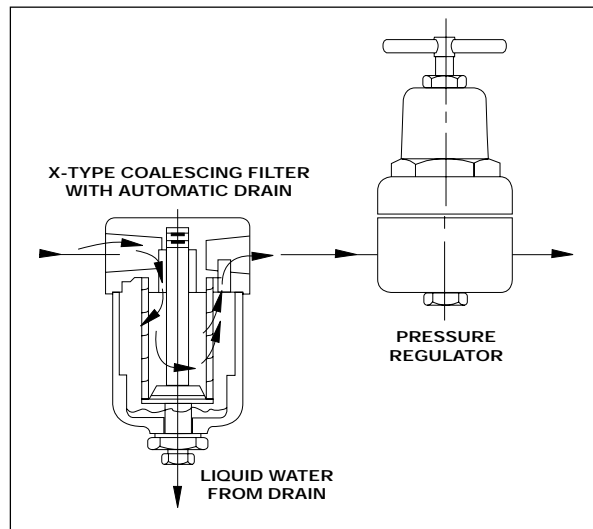

The solution to the condensed water problem (in a non-freezing environment) is to install a Balston coalescing filter (with an automatic drain) immediately upstream from the pressure regulator. The filter will remove all liquid water before the air enters the regulator, enhancing the full drying effect of pressure reduction. With the correct installation, there should be no need to use a dryer to prevent condensation in a system not subjected to freezing.

**6 Refrigeration Dryers**

As the name implies, refrigerated dryers work by cooling the air to low temperatures; thus condensing much of the water vapor. It is not possible to achieve dewpoints below freezing with this type of dryer. Optimally designed refrigerant dryers can produce air with dewpoints to approximately 36°F (2°C).

The most sophisticated refrigerant dryers remove the heat from the inlet air and use it to reheat the air at the outlet. Dried air is returned to the air line at reasonable temperatures. The advantages of heating the outlet air are clear: this process eliminates condensation from occurring when exposed to cold pipes. Self-contained refrigerant dryers use fans to cool the refrigerant condenser and automatic control systems to provide the exact heat exchange required by the air being used. These systems keep the delivered air at a constant humidity or dewpoint. Coalescing filters upstream (Balston Grade DXE) are required to prevent oil/liquid water from entering the dryer. Oil coating the cooling surfaces causes loss of efficiency and liquid water absorbs some of the system capacity.

Clearly, dewpoints of 40-44°F would prevent further condensation under most conditions of use (except freezing temperatures). Some water vapor is left in the air, which prevents these dryers from being used in water sensitive applications. A mainline membrane air dryer is capable of delivering 35°F Dewpoint air and should be considered for these applications as well.

## 7 Chemical Dryers

Some chemicals react with water and attract it from the air surrounding them. These chemicals are termed **hygroscopic** and examples are calcium chloride and lithium chloride. The air passed over the beds of these chemicals gives up water vapor, which steadily saturates the chemicals until they are used up and discarded. They are more difficult to control and give less predictable results. A reduction of 27°F in dewpoint compared to the inlet is about the best achievable. High efficiency coalescing filters (DXE followed by BXE) are absolutely essential upstream from a chemical dryer since the life of the chemicals is seriously reduced if liquid water enters the dryer. Downstream, a particle removal filter (DXE) is needed to prevent carryover of chemical fines.

## 8 Desiccant Dryers

Desiccant materials absorb water vapor molecules. These molecules are held by electrical forces. The process is reversible, and when the pores contain enough water vapor, exposure to heat or dry air will cause the water vapor to be released. Desiccant dryers are capable of delivering air at consistently low dewpoints, typically -40°F or less. This technology is a good choice when the compressed air will be exposed to freezing conditions. A membrane air dryer is also capable of delivering -40°F dewpoint air and should be considered for these applications as well.

In desiccant dryers, the compressed air is passed over one bed of material, which is in service. As the bed capacity is slowly used up, the performance of the dryer changes little (until it is near to saturation when the drying effect falls off significantly). Before this saturation point is reached, however, the air flow is switched to a second dry bed of material. The first bed is then regenerated, and the method employed (heat or dry air) is used to define the dryer. The regeneration phase of desiccant drying can be controlled by time or dewpoint measurement. Therefore, either timers or hygrometry (dewpoint monitoring) equipment can be used to control the regeneration of the dryer.

**Heated desiccant dryers** use heat to remove water vapor from the desiccant material in the dryer bed not in use at that point in the cycle. In heated desiccant dryers, heat is applied for 75% of the cycle, and the bed is allowed to cool for the remaining 25% of the cycle. A great deal of steam or electricity is required to operate heated desiccant dryers.

**Heatless desiccant dryers** use the dry air generated by the desiccant dryer to remove water vapor from the desiccant material. The dry air is passed over the desiccant bed (not in use) and water vapor evaporates from the desiccant into the dry air stream. This moisture laden air is subsequently vented to the atmosphere. The major advantage to using heatless desiccant dryers is the reduced dependence on expensive utilities—namely steam, electricity, or other heat sources. Minimal electricity is required to run a heatless desiccant dryer. In some cases, heatless desiccant dryers can be pneumatically controlled and therefore be suitable for explosion-proof installations. The Balston line of regenerative desiccant dryers can be conveniently located near the point-of-use to deliver dry compressed air at dewpoints to  $-100^{\circ}\text{F}$  ( $-73^{\circ}\text{C}$ ). These dryers are wall-mountable and ideal for delivering instrument quality air for critical applications.

Overall, heatless desiccant dryers have an advantage over heated desiccant dryers in that they do not require excessive outside services, i.e., steam, electricity, or gas for heat, to generate dry air and regenerate the desiccant. In addition to reducing dependency on outside services, costs for operating these dryers are also reduced.

In both heated or heatless, desiccant dryers should be protected from liquid water by a coalescing filter installed upstream from the dryer. Oil or water entering the dryer will adversely affect the performance of the dryer and/or destroy the desiccant material. Furthermore, if oil enters a heated desiccant dryer, combustion of the desiccant material could occur. The Balston Grade DXE and Grade BXE coalescing filters, used in series upstream from the dryer, provide excellent protection of the dryer from contaminants in the compressed air supply. It is also good practice to install a filter downstream from the dryer (Balston<sup>®</sup> Grade BXE) to prevent any carryover of the desiccant to downstream equipment or processes.

## 9 Membrane Air Dryers

Membrane materials selectively permeable to water vapor are an excellent medium for producing dry air from standard compressed air. As the compressed air travels along the length of the membrane, water vapor diffuses through the membrane, producing clean, dry compressed air at the outlet. A small fraction of the dry air is then directed along the outside surface of the membrane to “sweep” the moisture-laden air away from the membrane. The water vapor concentration differential between the compressed air inside the membrane (high water vapor content) and “sweep” air outside the membrane (low water vapor content) enhances the drying characteristics of the membrane.

Coalescing filters should be installed upstream from a membrane dryer to protect the membrane from being saturated by water or coated by oil. If saturation or coating occurs, the membrane drying function could be seriously inhibited. In most cases, the Balston Grade BXE coalescing filter is ideal for installation upstream from a membrane dryer. When large quantities of liquids are expected, a Balston Grade DXE coalescing filter should also be installed (upstream from the Grade BXE filter). Parker offers a wide range of membrane dryers, conveniently installed for most point-of-use applications, which reduce dewpoints of incoming compressed air to -40°F (-40°C), depending on flow and pressure characteristics of the air.

### **Specifying the Right Dryer**

In specifying the right dryer for a compressed air installation, keep the following information in mind:

- 1** Do not overspecify - Drying the entire compressed air supply in a factory to dewpoints less than -40°F (-40°C) is wasteful. It is more sensible to subdivide the compressed air supply by application, treating each end use point as needed to provide appropriately dry air for the downstream application served.
- 2** Do not underspecify - Damage caused by wet air costs money in maintenance time and supplies, downtime, and lost product. Design a drying system to meet specific needs.
- 3** A drying system which only contains an aftercooler and a coalescing filter could create problems with condensation downstream from the aftercooler. The air is still saturated with vapor which is likely to condense if the ambient temperature is lower than the compressed air temperature.
- 4** Utilize the 'drying' effect of pressure reduction-For applications which use air at lower pressures than the main compressed air line and will tolerate some water vapor, install filters or filter-regulators at the point of use to maximize the 'drying' effect of pressure reduction.
- 5** Specify membrane dryers for those parts of the system which require dewpoints of 35°F - 52°F (2°C - 5°C) and flow rates up to 1200 SCFM.
- 6** Specify membrane dryers for instrument quality air, air exposed to freezing temperatures, and water sensitive applications requiring flow rates up to 100 scfm. Typically, compressed air with a dewpoint of -40°F (-40°C) is reasonable for these water vapor sensitive applications.

## How We Provide High Efficiency Plus Low Pressure Drop

Balston filter assemblies derive their unique advantage from the proprietary Microfibre Filter cartridges, which are constructed from borosilicate glass fibers with a chemically-resistant fluorocarbon resin binder. The Microfibre Filter cartridges are self-supporting and self-gasketing - they are sealed in place by compression against the flat surfaces of the filter housing and/or element retainer.

Here's how this unique filter medium delivers its unusually advantageous performance.

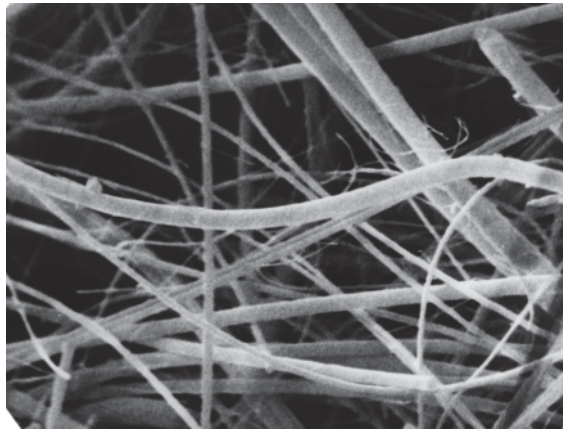

Figure 4 - Photomicrograph of microfibre filter cartridge

### Collision, Not Sieving

A Microfibre Filter (Figure 4) is constructed of a random bed of borosilicate glass fibers, held in a rigid structure by the fluorocarbon resin binder. The diameter of the fibers in the photograph is approximately one micron: the spaces between the fibers are much larger. How, then, can the filter capture contaminants smaller than one micron with very high efficiency? Clearly, the Microfibre Filter cartridge does not capture by a "sieving" action (holding back particles too large to pass between the fibers). Rather, when a solid particle or liquid droplet collides with a fiber it adheres permanently to the fiber by intermolecular (Van der Waals) forces.

The intermolecular forces are effective for any type of particle or liquid droplet, at any relative humidity or temperature. After a particle is captured, it cannot be dislodged by shaking or vibration. As a result, the filter will not suddenly unload the contaminants downstream when there is a surge in flow. This permanent adherence principal, however, prevents cleaning the cartridge by back-washing.

### Momentum and Brownian Motion

The larger particles and droplets in the gas stream have sufficient momentum to collide with one of the many fibers in the flow path. The right-hand dotted line in Figure 5 shows schematically the efficiency of capture by the momentum capture mechanism. (Please note the vertical scale on the chart in the high efficiency range is greatly expanded to illustrate the discussion.)

In filtration of gases - not in filtration of liquids - we benefit from a second mechanism of particle capture - Brownian Motion. Brownian Motion is the rapid, random motion of particles, 0.1 micron and smaller, in a gas. The movement is completely independent of the overall gas flow direction, and occurs even when the gas as a whole is not flowing.

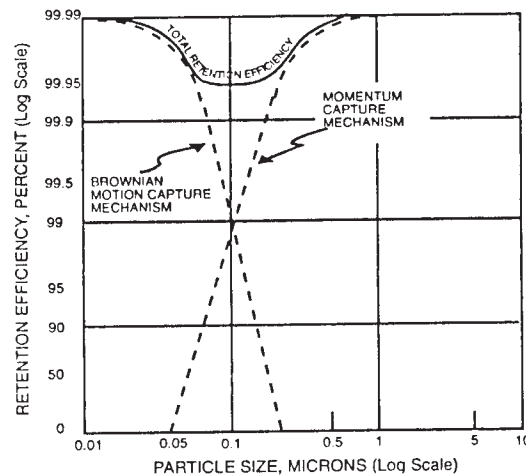

Figure 5 - General retention efficiency curve for microfibre filter cartridge

Obviously, a particle subject to rapid side-to-side motion in a gas flowing through a fiber filter has a very high probability of contacting a fiber and being captured. Therefore, as shown by the left hand dotted line in the figure, Brownian Motion is extremely effective as a capture mechanism for particles smaller than 0.1 micron, and less effective as particle sizes increase to and beyond 0.1 micron. The total efficiency is the sum of the capture efficiency by the momentum capture mechanism and by Brownian Motion. The result is a curve with maximum efficiencies at both above 1 micron and below 0.05 micron, with a dip in efficiency at 0.1 micron.

Balston air and gas filters are rated for retention efficiencies at the crucial 0.1 micron particle size. As shown by Figure 5, the filters will be more efficient than these ratings at any other particle size, larger or smaller. For complete data on the efficiencies of all Balston gas filter grades over the range 0.035 to 0.7 micron (measured by Dr. B. Y. H. Liu, Director of University of Minnesota Particle Technology Laboratory), please request Bulletin TI-105.

### The Filter is Mostly Voids

It is also important to note that the filter is very largely void volume (as seen in the photomicrograph of Figure 4). In fact, the filter media in Balston Microfibre Filter cartridges is approximately 95% void volume and only 5% fiber volume. This results in exceptionally low flow resistance (pressure drop) and exceptionally high solids-holding capacity for longer service life than other types of high efficiency filters.

## How a Balston Filter Removes Liquid Droplets

### Making Big Drops from Little Ones: "Coalescing"

In the discussion of the retention efficiency of the microfibre filter cartridge, there was no distinction made between solid particles and liquid droplets. Both are captured at the same efficiencies. However, once captured on the fibers, the two types of contaminants behave differently.

A solid particle, once captured, cannot be removed. A liquid droplet, however, runs down the length of the fiber until it reaches a fiber crossover point. When many liquid droplets run together, the liquid collected at the fiber crossover point becomes a larger droplet. The larger droplet is then gradually pushed through the fiber mat by the flow of air or gas, picking up other droplets along the way, until it appears as a very large droplet on the downstream surface of the filter. Thus, the filter removes very fine liquid droplets from the gas stream and converts them into large droplets of liquid, which can be readily drained from the system. This process is called "coalescing".

### Why Inside-To-Outside Flow?

Since the coalesced liquid appears on the downstream surface after having passed completely through the filter, the liquid will drip from this surface. In all Balston coalescing filters, the flow direction through the filter cartridge is inside-to-outside. The coalesced liquid drains from the outside surface of the filter cartridge; therefore, provisions must be made to drain the liquid from the housing. (See Figure 6). A Microfibre filter will coalesce liquid droplets indefinitely without loss of efficiency or flow capacity, because the liquid drains from the filter cartridge as rapidly as it is collected. Only solid particles will cause a permanent increase in flow resistance; therefore, the useful life of the filter is determined by the quantity of solids in the gas, not by the quantity of liquid in the gas.

Since the coalesced liquid drips off the downstream surface of the filter cartridge in the presence of filtered air, it is important to avoid carryover, or entrainment, of liquid droplets by the air leaving the filter housing.

### Balston X-Type Microfibre Filter Cartridges

The X-Type filter cartridges are designed to prevent carryover of coalesced liquid. They are constructed of two layers, an inner high-efficiency coalescing layer, and an outer layer of coarse glass fibers. The coarse, rapidly-draining outer layer ensures that the liquid drips continuously from the bottom of the filter cartridge and minimizes the chance of liquid carryover. When an X-Type Microfibre filter cartridge has reached steady state coalescing conditions, only the bottom 5-10 mm of the filter cartridge is visibly wet, and the rest of the cartridge appears to be dry. This effect is caused by the liquid droplets coalescing in the inner layer, which then rapidly drain down within the coarse outer layer, and the filtered air or gas exits from the dry outer surface of the filter cartridge with virtually no chance of picking up coalesced liquid.

### How to Obtain a Trouble-Free Coalescer

The mechanism of coalescing leads to three important considerations in selecting and installing a coalescing filter:

- 1 The filter should be large enough to ensure that air exits the filter at low velocity and does not carry over coalesced liquid. Proper sizing of a Balston coalescing filter is easily done by using the recommendations or the maximum flow rate data in the charts given in the product literature. There is no danger in over-sizing the filter – a Balston coalescing filter is even more efficient at extremely low flow rates than at its maximum rated flow capacity.
- 2 To avoid liquid carryover, the coalesced liquid should not be allowed to build up in the filter housing above the level of the bottom of the filter cartridge. Rather than relying on operator attention to this easily-overlooked job, automatic drains should be installed with all coalescing filters.
- 3 The flow direction through the Microfibre filter cartridge must be inside-to-outside to permit the liquid to drip from the outside of the cartridge to the drain into the filter housing. If installed outside-to-inside, the filter will at first function as a coalescing filter, but liquid will collect on the inside of the filter cartridge. Since there is no way of draining the liquid, the level will build up rapidly until it begins to be carried downstream by the gas flow. The filter will work well at removing liquids for a short time, and then not work at all. If a Balston coalescing filter exhibits these symptoms, reversing the flow direction will provide the cure.

Figure 6 - The Coalescing Principle

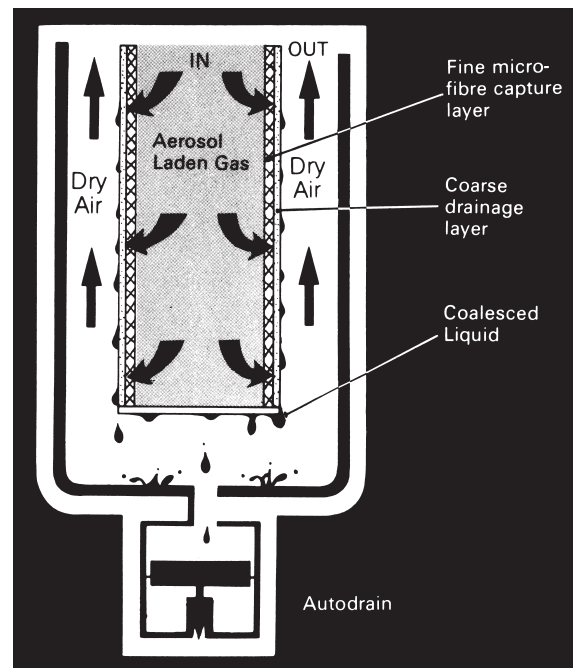

## Removing Oil from Compressed Air

The source of oil in compressed air is the compressor lubricant. The common plant problems resulting from oil in the compressed air are caused by liquid oil depositing in valves, on instrument control surfaces, and in other critical points in the air distribution system.

The most common concern about oil vapor in most applications is that it may condense to liquid oil. Just like water vapor, oil vapor will condense to liquid when the temperature is reduced or the air pressure is increased (at a constant temperature). The table at right shows that in theory, the condensation of oil vapor and water vapor are similar, in practice the effect of condensation of the two vapors is quite different.

From the table figures, we can calculate that if 3500 cu ft./hr. of air at 122°F (50°C) is filtered to remove all liquids and subsequently cooled to 77°F (25°C), the condensed liquids would consist of: 950 g per hour (2743 ppm) of water, and either 0.25g per hour (.012 ppm) of petroleum-based oil, or 0.1g per hour (.002 ppm) of synthetic oil. The condensed water could potentially cause a serious problem, but the quantity of condensed oil vapor is extremely small and less likely to be problematic.

Field tests show that the liquid oil in air from a well-maintained reciprocating compressor is typically in the range of 15 to 30 ppm. With an oil-sealed rotary screw compressor, liquid oil content in the compressed air can vary from 10 ppm to more than 100 ppm, depending upon the efficiency of the bulk oil separator. Compared to these figures, the approximately 0.2 ppm of liquid oil which could result from oil vapor condensation is, for all practical purposes, negligible.

Removing the liquid oil from compressed air with a Balston coalescing filter, even at temperatures as high as 122°F (50°C), will eliminate the chance of oil-based problems downstream in virtually all installations.

There are some instances, however, in which even 0.2 ppm oil vapor in the air or gas can cause a problem; for example, if allowed to be in contact with a sensitive catalyst or other highly reactive material. In these cases, the trace quantity of oil vapor can be reduced using an absorbent-loaded cartridge downstream from the coalescing filters which remove the liquid oil.

	Concentration of vapor, parts per million by weight (ppm) in air at 101 psig (7 bar) at indicated temperature.				
	77°F (25°C)	104°F (40°C)	122°F (50°C)	149°F (65°C)	203°F (95°C)
<b>Petroleum-base oil</b>	0.012	0.05	0.2	0.7	3.5
<b>Synthetic Oil</b>	0.002	0.01	0.06	0.2	2.4
<b>Water</b>	2,743	5,137	10,508	20,119	62,371

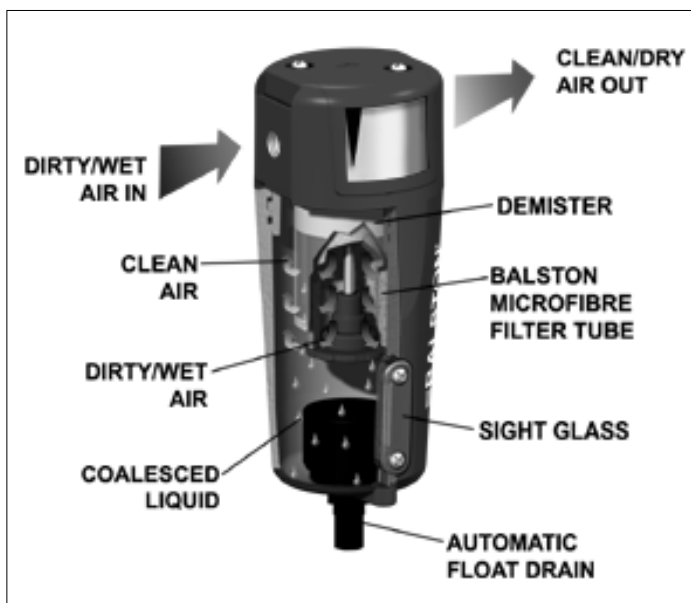

Figure 7 - Balston Compressed Air Filter with Microscreen Demister



**Parker Hannifin Corporation**  
 Filtration and Separation Division  
 242 Neck Road, P.O. Box 8223  
 Haverhill, MA 01835-0723  
 Tel: 978-858-0505 Fax: 978-858-0625

**Parker Hannifin UK Ltd**  
 Filter Division Europe  
 Hermitage Court, Hermitage Lane  
 Maidstone, Kent ME16 9NT, England  
 Tel: +44 (0) 1622-723300 Fax: +44 (0) 1622-728703

