



aerospace
climate control
electromechanical
filtration
fluid & gas handling
hydraulics
pneumatics
process control
sealing & shielding



High Efficiency, Food Grade Nitrogen Gas Generators for the Food and Beverage Processing Industry

Bulletin LGN2FD09-A



ENGINEERING YOUR SUCCESS.

Balston Filtration and Gas Generation Systems

Clean Compressed Air and Gases for Contaminant-Free Applications

We engineer the success of our customers around the world, drawing upon nine core motion and control technologies. These technologies enable virtually every machine and process to operate accurately, efficiently and dependably.

As the global leader in motion and control, we partner with our distributors to increase our customers' productivity and profitability by delivering an unmatched breadth of engineered components and value-added services.

We continue to grow with our customers by creating application-focused products and system solutions. A key to our global expansion has been to follow our customers and establish operations, sales and service wherever they are needed. No single competitor matches Parker's global presence, which includes:

Parker's Motion and Control Technologies:

| | |
|----------------------|---------------------|
| Aerospace | Hydraulics |
| Climate Control | Pneumatics |
| Electromechanical | Process Control |
| Filtration | Sealing & Shielding |
| Fluid & Gas Handling | |

- **+\$10 Billion Sales**
- **900,000 Products**
- **427,000 Customers**
- **52,000 Employees**
- **12,000 Distribution MRO Outlets**
- **1,200 Markets**
- **287 Manufacturing Plants**
- **125 Divisions**
- **9 Technologies**

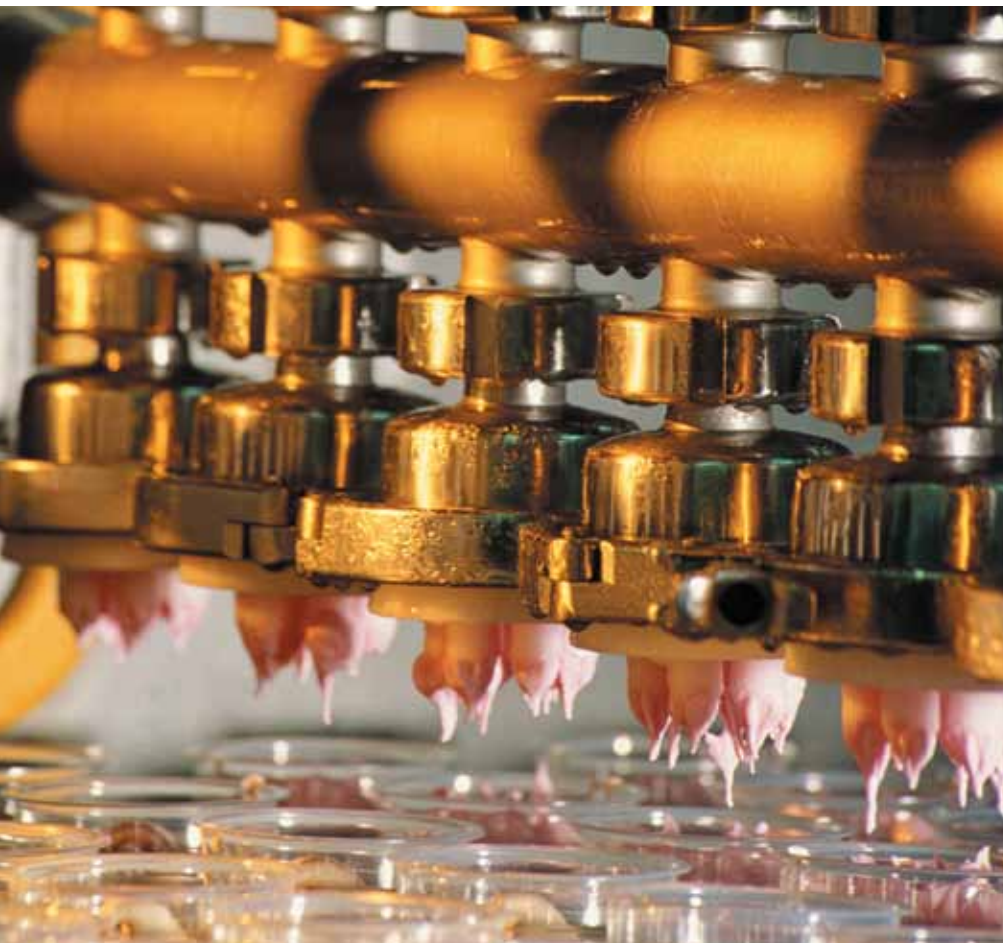

Corporate Headquarters in Cleveland, Ohio



High Efficiency, Food Grade Nitrogen Gas Generators

Performance under pressure

Nitrogen is widely used in food operations to extend shelf-life, minimize spoilage, prevent bacteria growth, and eliminate moisture.



Applications:

- Blanketing
- Bottling
- Modified Air Packaging (MAP)
- Wine Bottling and Processing
- Beer Dispensing
- Inert Conditions of Plant Storage Facility

What Separates Parker Nitrogen Gas Generators From The Competition?



Parker's Nitrogen Systems are customizable - our team of engineers will work with you to meet your specific requirements.



Energy Efficient Control System

Traditional PSA systems operate under a fixed time cycle even when customer nitrogen demand is low. This is very wasteful since it requires compressors to produce large amounts of air to feed the PSA. The Energy Efficient Control System (EECS) utilizes the on board nitrogen flow meter to monitor customer demand of nitrogen. During periods of low demand, the time cycle will automatically extend which reduces the air requirement to the PSA when compared to a 60 second fixed time cycle. This ultimately results in an energy savings since the air compressor does not have to stay continuously loaded requiring less kilo-watts consumed by the compressor. As an added benefit, valve life can also be extended since the valves are switching less.

Differential Pressure Bed Monitoring

Differential pressure indicators are included to allow the user to monitor excessive differential pressures across the bed. This is important since high differential pressures can lead fluidization of the CMS inside the adsorption vessels.

L/D ratios

Beds are sized to maintain a specific length-to-diameter ratio. Proper L/D is critical to prevent feed gas channeling making the nitrogen separation process inefficient. Optimum L/D is calculated to minimize the channeling effect so maximum bed surface area is realized.

Valve Leak Check

Incorporated in the system is a Valve Leak Check step which allows the user to determine valve seat health without having to remove the valves from the process. Valve Leak Check can be performed and completed in less than 10 minutes.

PSA Standby

Separate from the EECS controls is a Standby feature. If nitrogen is no longer required for a period of time, the control system detects a no flow condition which will result in the PSA entering a sleep mode or Standby. This will shut the system down which will in turn time-out the air compressors so they are not continuing to run unnecessarily. This will also improve valve seat life since they are no longer cycling. Once the control system detects nitrogen flow the system automatically starts back up and seamlessly resumes nitrogen production.

Bed Design

Our PSA vessels can be reloaded, unlike some of our competitors. We utilize an ASME flanged on top of the dual bed design (Carbon Molecular Sieve). Some competitors use welded tops and non ASME.

The nitrogen generation process takes the air we breath and recovers the nitrogen via PSA or membrane technology.

Recover the heat generated from the compressor and use it to heat your facility for additional savings

Parker Nitrogen Generation Systems will continuously produce high purity, food grade nitrogen from an existing compressed air source. For applications without a compressed air source, models are available with compressors.

A Parker Nitrogen System will eliminate the inconvenience and high costs associated with nitrogen cylinders, dewars, and bulk delivery. The hassles of changing high pressure cylinders and interruption of gas supply are completely removed. A Parker Nitrogen Generator offers long term price stability eliminating uncontrollable vendor price increases, long term commitments, contract negotiations and tank rental fees. A continuous supply of consistent purity nitrogen is available within minutes of startup.

Installation is simple: pipe in compressed air and pipe out nitrogen. Just connect a standard compressed air line to the inlet of the generator, connect the outlet to your nitrogen line and the unit is ready for trouble-free operation. The system is designed to operate 24 hours a day, 7 days a week. If no compressed air is available, Parker offers models that include compressors.

There is no complicated operating procedure or labor intensive monitoring involved. Simply select the purity your process requires and set the flow. Within minutes, high purity, dry nitrogen is available.

Features:

- Ensure food safety
- Eliminate the need for costly delivered nitrogen
- No operation attention required
- Minimal maintenance
- Membrane and PSA units available
- Purities from 95% - 99.5% plus
- Lower cost than purchasing nitrogen from vendors
- Operate continuously with no unexpected shutdowns
- Hassle-free, easy to operate and install
- Compact, frees up valuable floor space
- Safe and reliable
- Stable, long term nitrogen costs

Benefits:

- Lower cost, eliminates the need for costly cylinders or bulk liquid systems (as much as 50% plus savings).
- Compact, frees up valuable floor space when compared to cylinders.
- Eliminates unexpected shutdowns due to "bad, empty cylinders or truck delivery delays.
- No possible contamination when compared to bulk liquid being delivered (liquid spills).
- Hassle-free, easy to install and operate.
- Safe and reliable.
- No long term contracts to deal with
- Environmentally safe - no tanker deliveries, no greenhouse gas emissions



Membrane Nitrogen Generators



Benefits:

- Reduce system costs
- Reduce operational costs
- Increase system reliability
- Long Fiber Life
- Highly Reliable
- No performance loss due to fiber aging

Membrane Technical Advantages

Requires low compressed air pressure and a standard air compressor to produce nitrogen.

Parker HIFLUXX® nitrogen membranes do not require a “heater” to enhance membrane performance. This is based on the innovative Polymer design “Poly Phenylene Oxide” which is a very strong plastic, not sensitive to particle contamination and lowest pressure drop.

Benefits of HIFLUXX® technology include high permeability, compact module size, performance at “low pressures” and reduced pressure drop.

Parker HIFLUXX® membrane is 100 times more permeable than the lowest permeable competitor and significantly more permeable than all other membranes for the application.

Results in higher nitrogen production from a given size fiber and a Parker membrane module which is less than half the size of other suppliers’ modules with equal performance. Another benefit of the high permeability is production of nitrogen at a reduced air pressure, resulting in significantly “lower energy usage”. No need for expensive, long lead custom high pressure air compressors.



How Membrane Technology Works

Parker Balston nitrogen generators utilize proprietary membrane separation technology. The membrane separates compressed air into two streams: one is 95%-99% pure nitrogen, and the other is oxygen enriched with carbon dioxide and other gases.

The generator separates air into component gases by passing in-expensive compressed air through semi permeable membranes, consisting of bundles of individual hollow fibers. Each fiber has a perfectly circular cross section and a uniform bore through its center. Because the fibers are so small, a great many can be packed into a limited

space, providing an extremely large membrane surface area that can produce a relatively high volume product stream.

Compressed air is introduced into the center of the fibers at one end of the module and contacts the membrane as it flows through the fiber bores. Oxygen, water vapor and other trace gases easily permeate the membrane fiber and are discharged through a permeate port while the nitrogen is contained within the membrane and flows through the outlet port. Since water vapor permeates through the membrane as well, the nitrogen gas stream is very dry, with dewpoints as low -58°F.

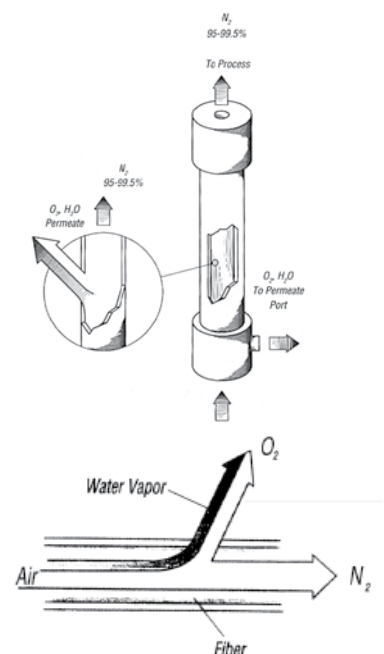

Membrane Nitrogen Generators

HiFluxx® Series

Through Parker's advanced membrane technology we are able to separate the oxygen from nitrogen efficiently and produce a very high volume of nitrogen flow.

Principal Specifications

Membrane Nitrogen Generators

| | |
|---|----------------------|
| Atmospheric Dewpoint | -58°F (-50°C) |
| Particles > 0.01 micron | None |
| Suspended Liquids | None |
| Recommended Inlet Pressure | 110 psig (7.6 barg) |
| Max Outlet Pressure at Corresponding Purity | 80 psig @ 95% - 97% |
| Min/Max Ambient Temperature | 40°F/95°F (4°C/35°C) |
| Electrical Requirements | 120VAC/60 Hz. |

Nitrogen Purity Flow Chart

Membrane Nitrogen Gas Generators

| Model Number | Flow Rate (SCFM) | Feed Pressure (PSIG) | Delivery Pressure (PSIG) | Dimensions (L x W x H, ft.) | Weight (lbs.) |
|---------------|------------------|----------------------|--------------------------|-----------------------------|---------------|
| FB-ST15020-3 | 250 | 125 | 80 | 13'-6" x 6'-6" x 5'-0" | 3,800 |
| FB-ST15020-4 | 500 | 125 | 80 | 13'-6" x 6'-6" x 8'-0" | 5,500 |
| FB-ST15020-10 | 1,000 | 125 | 80 | 15'-0" x 8'-0" x 8'-0" | 6,500 |

Notes

- 1 Produces 95% Plus Pure Nitrogen; many other flow rates and delivery pressures to choose from.
- 2 Also available for out door installations. Dimensions and weights may vary depending on specific flow and purity.



PSA Nitrogen Generators

Monobed and Dual Bed Designs



Model PSA-176-0.5

Features:

- Produces 95-99.5% plus pure, commercially sterile nitrogen
- Many flows and purities to choose from

How PSA Technology Works

Balston Monobed and Dual Bed Nitrogen Generators produce up to 99.999% pure, compressed nitrogen at dewpoints to -58°F (-50°C) from nearly any compressed air supply. The generators are designed to continually transform standard compressed air into nitrogen at safe, regulated pressures without operator attention.

Balston PSA Nitrogen Generators utilize a combination of filtration and pressure swing adsorption technologies. High efficiency prefiltration pretreats the compressed

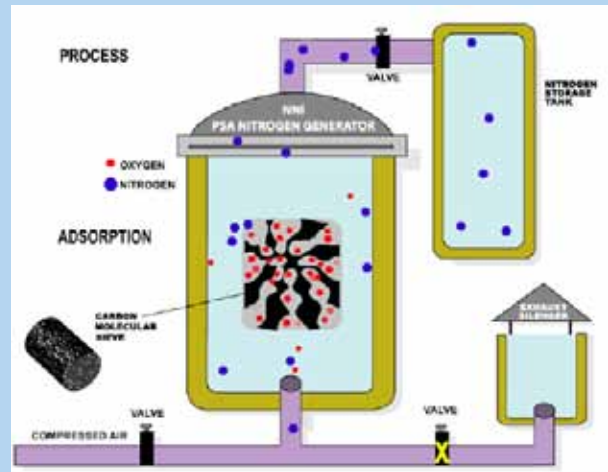

air to remove all contaminants down to 0.1 micron. Air entering the generator consists of 21% oxygen and 78% nitrogen. The gas separation process preferentially adsorbs oxygen over nitrogen using carbon molecular sieve (CMS). At high pressures the CMS has a greater affinity for oxygen, carbon dioxide, and water vapor than it does at low pressures. By raising and lowering the pressure within the CMS bed, all contaminants are captured and released, leaving the CMS unchanged. This process allows the nitrogen to pass through as a product gas at pressure. The depressurization phase of the CMS releases the absorbed oxygen and other contaminant gases to the atmosphere.



PSA Nitrogen Generators Dual Bed Series

The generators are designed to continually transform standard compressed air into nitrogen at safe, regulated pressures without operator attention.

Principal Specifications

Dual Bed Nitrogen Generators

| | |
|---|----------------------|
| Atmospheric Dewpoint | -58°F (-50°C) |
| Particles > 0.01 micron | None |
| Suspended Liquids | None |
| Recommended Inlet Pressure | 110 psig (7.6 barg) |
| Max Inlet Pressure | 140 psig (9.7 barg) |
| Max Outlet Pressure at Corresponding Purity | 80 psig @ 99.999% |
| Min/Max Ambient Temperature | 40°F/95°F (4°C/35°C) |
| Electrical Requirements | 120VAC/60 Hz. |

Nitrogen Purity Flow Chart

Food Grade (99.5%) High Purity Nitrogen Gas Generator Skids

| Model Number | Flow Rate (SCFH) | Feed Pressure (PSIG) | Delivery Pressure (PSIG) | Dimensions (L x W x H, ft.) | Weight (lbs.) |
|--------------|------------------|----------------------|--------------------------|-----------------------------|---------------|
| PSA-118-0.5 | 8,000 | 125 | 80 | 11'-0" x 6'-6" x 12'-6" | 12,000 |
| PSA-147-0.5 | 10,000 | 125 | 80 | 11'-0" x 6'-6" x 13'-5" | 13,500 |
| PSA-176-0.5 | 12,000 | 125 | 80 | 11'-0" x 6'-6" x 14'-3" | 13,000 |
| PSA-220-0.5 | 15,000 | 125 | 80 | 12'-9" x 8'-0" x 14'-0" | 18,000 |
| PSA-294-0.5 | 20,000 | 125 | 80 | 13'-0" x 8'-3" x 15'-6" | 18,700 |
| PSA-367-0.5 | 25,000 | 125 | 80 | 13'-0" x 8'-3" x 16'-6" | 19,900 |
| PSA-441-0.5 | 30,000 | 125 | 80 | 16'-0" x 9'-6" x 15'-6" | 36,000 |
| PSA-588-0.5 | 40,000 | 125 | 80 | 16'-0" x 10'-0" x 18'-6" | 37,000 |

Notes

- 1 Produces 95% - 99.999% Pure Nitrogen; many other flow rates and delivery pressures to choose from.
- 2 Also available for out door installations. Dimensions and weights may vary depending on specific flow and purity.

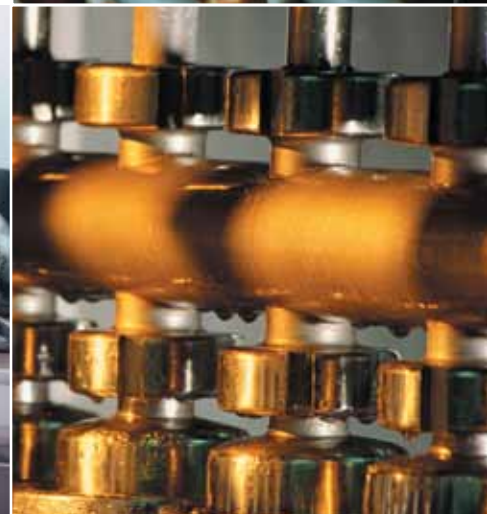

Offer of Sale

The items described in this document are hereby offered for sale at prices to be established by Parker Hannifin Corporation, its subsidiaries and its authorized distributors. This offer and its acceptance by any customer ("Buyer") shall be governed by all of the following Terms and Conditions. Buyer's order for any item described in its document, when communicated to Parker Hannifin Corporation, its subsidiary or an authorized distributor ("Seller") verbally or in writing, shall constitute acceptance of this offer.

1. Terms and Conditions of Sale: All descriptions, quotations, proposals, offers, acknowledgments, acceptances and sales of Seller's products are subject to and shall be governed exclusively by the terms and conditions stated herein. Buyer's acceptance of any offer to sell is limited to these terms and conditions. Any terms or conditions in addition to, or inconsistent with those stated herein, proposed by Buyer in any acceptance or an offer by Seller, are hereby objected to. No such additional, different or inconsistent terms and conditions shall become part of the contract between Buyer and Seller unless expressly accepted in writing by Seller. Seller's acceptance of any offer to purchase by Buyer is expressly conditional upon Buyer's assent to all the terms and conditions stated herein, including any terms in addition to, or inconsistent with those contained in Buyer's offer. Acceptance of Seller's products shall in all events constitute such assent.

2. Payment: Payment shall be made by Buyer within 30 days from the date of shipment. Amounts not timely paid shall bear interest at the Maximum rate permitted by law for each month or portion thereof that the Buyer is late making payment. Any claims by Buyer for omissions or shortages in a shipment shall be waived unless Seller receives notice thereof within 30 days after Buyer's receipt of the shipment.

3. Delivery: Unless otherwise provided on the face hereof, delivery shall be made F.O.B. Seller's plant. Regardless of the method of delivery, however, risk of loss shall pass to Buyer upon Seller's delivery to a carrier. Any delivery dates shown are approximate only and Seller shall have no liability for any delays in delivery.

4. Warranty: Seller warrants that the items sold hereunder shall be free from defects in material or workmanship for a period of 18 months from date of shipment to Buyer. THIS WARRANTY COMPRISES THE SOLE AND ENTIRE WARRANTY PERTAINING TO ITEMS PROVIDED HEREUNDER. SELLER MAKES NO OTHER WARRANTY, GUARANTEE, OR REPRESENTATION OF ANY KIND WHATSOEVER. ALL OTHER WARRANTIES, INCLUDING BUT NOT LIMITED TO, MERCHANTABILITY AND FITNESS FOR PURPOSE, WHETHER EXPRESS, IMPLIED, OR ARISING BY OPERATION OF LAW, TRADE USAGE, OR COURSE OF DEALING ARE HEREBY DISCLAIMED.

NOTWITHSTANDING THE FOREGOING, THERE ARE NO WARRANTIES WHATSOEVER ON ITEMS BUILT OR ACQUIRED WHOLLY OR PARTIALLY, TO BUYER'S DESIGNS OR SPECIFICATIONS.

5. Limitation of Remedy: SELLER'S LIABILITY ARISING FROM OR IN ANY WAY CONNECTED WITH THE ITEMS SOLD OR THIS CONTRACT SHALL BE LIMITED EXCLUSIVELY TO REPAIR OR REPLACEMENT OF ITEMS SOLD OR REFUND OF THE PURCHASE PRICE PAID BY BUYER, AT SELLER'S SOLE OPTION. IN NO EVENT SHALL SELLER BE LIABLE FOR ANY INCIDENTAL, CONSEQUENTIAL OR SPECIAL DAMAGES OF ANY KIND OR NATURE WHATSOEVER, INCLUDING BUT NOT LIMITED TO LOST PROFITS ARISING FROM OR IN ANY WAY CONNECTED WITH THIS AGREEMENT OR ITEMS SOLD HEREUNDER, WHETHER ALLEGED TO ARISE FROM BREACH OF CONTRACT, EXPRESS OR IMPLIED WARRANTY, OR IN TORT, INCLUDING WITHOUT LIMITATION, NEGLIGENCE, FAILURE TO WARN OR STRICT LIABILITY.

6. Changes, Reschedules and Cancellations: Buyer may request to modify the designs or specifications for the items sold hereunder as well as the quantities and delivery dates thereof, or may request to cancel all or part of this order, however, no such requested modification or cancellation shall become part of the contract between Buyer and Seller unless accepted by Seller in a written amendment to this agreement. Acceptance of any such requested modification or cancellation shall be at Seller's discretion, and shall be upon such terms and conditions as Seller may require.

7. Special Tooling: A tooling charge may be imposed for any special tooling, including without limitation, dies, fixtures, molds and patterns, acquired to manufacture items sold pursuant to this contract. Such special tooling shall be and remain Seller's property notwithstanding payment of any charges by Buyer. In no event will Buyer acquire any interest in apparatus belonging to Seller which is utilized in the manufacture of the items sold hereunder, even if such apparatus has been specially converted or adapted for such manufacture and notwithstanding any charges paid by Buyer. Unless otherwise agreed, Seller shall have the right to alter, discard or otherwise dispose of any special tooling or other property in its sole discretion at any time.

8. Buyer's Property: Any designs, tools, patterns, materials, drawings, confidential information or equipment furnished by Buyer or any other items which become Buyer's property, may be considered obsolete and may be destroyed by Seller after two (2) consecutive years have elapsed without Buyer placing an order for the items which are manufactured using such property. Seller shall not be responsible for any loss or damage to such property while it is in Seller's possession or control.

9. Taxes: Unless otherwise indicated on the face hereof, all prices and charges are exclusive of excise, sales, use, property, occupational or like taxes which may be imposed by any taxing authority upon the manufacture, sale or delivery of the items sold hereunder. If any such taxes must be paid by Seller or if Seller is liable for the collection of such tax, the amount thereof shall be in addition to the amounts for the items sold. Buyer agrees to pay all such taxes or to reimburse Seller therefore upon receipt of its invoice. If Buyer claims exemption from any sales, use or other tax imposed by any taxing authority, Buyer shall save Seller harmless from and against any such tax, together with any interest or penalties thereon which may be assessed if the items are held to be taxable.

10. Indemnity For Infringement of Intellectual Property Rights: Seller shall have no liability for infringement of any patents, trademarks, copyrights, trade dress, trade secrets or similar rights except as provided in this Part 10. Seller will defend and indemnify Buyer against allegations of infringement of U.S. patents, U.S. trademarks, copyrights, trade dress and trade secrets (hereinafter 'Intellectual Property Rights'). Seller will defend at its expense and will pay the cost of any settlement or damages awarded in an action brought against Buyer based on an allegation that an item sold pursuant to this contract infringes the Intellectual Property Rights of a third party. Seller's obligation to defend and indemnify Buyer is contingent on Buyer notifying Seller within ten (10) days after Buyer becomes aware of such allegations of infringement, and Seller having sole control over the defense of any allegations or actions including all negotiations for settlement or compromise. If an item sold hereunder is subject to a claim that it infringes the Intellectual Property Rights of a third party, Seller may, at its sole expense and option, procure for Buyer the right to continue using said item, replace or modify said item so as to make it noninfringing, or offer to accept return of said item and return the purchase price less a reasonable allowance for depreciation. Notwithstanding the foregoing, Seller shall have no liability for claims of infringement based on information provided by Buyer, or directed to items delivered hereunder for which the designs are specified in whole or part by Buyer, or infringements resulting from the modification, combination or use in a system of any item sold hereunder. The foregoing provisions of this Part 10 shall constitute Seller's sole and exclusive liability and Buyer's sole and exclusive remedy for infringement of Intellectual Property Rights.

If a claim is based on information provided by Buyer or if the design for an item delivered hereunder is specified in whole or in part by Buyer, Buyer shall defend and indemnify Seller for all costs, expenses or judgments resulting from any claim that such item infringes any patent, trademark, copyright, trade dress, trade secret or any similar right.

11. Force Majeure: Seller does not assume the risk of and shall not be liable for delay or failure to perform any of Seller's obligations by reason of circumstances beyond the reasonable control of Seller (hereinafter 'Events of Force Majeure'). Events of Force Majeure shall include without limitation, accidents, acts of God, strikes or labor disputes, acts, laws, rules or regulations of any government or government agency, fires, floods, delays or failures in delivery of carriers or suppliers, shortages of materials and any other cause beyond Seller's Control.

12. Entire Agreement/Governing Law: The terms and conditions set forth herein, together with any amendments, modifications and any different terms or conditions expressly accepted by Seller in writing, shall constitute the entire Agreement concerning the items sold, and there are no oral or other representations or agreements which pertain thereto. This Agreement shall be governed in all respects by the law of the State of Ohio. No actions arising out of the sale of the items sold hereunder or this Agreement may be brought by either party more than two (2) years after the cause of action accrues.



Parker Hannifin Corporation
Filtration Group
Global Headquarters
 6035 Parkland Boulevard
 Cleveland, OH 44124-4141
 T 216 896 3000, F 216 896 4021
www.parker.com

North America

Compressed Air Treatment
Filtration & Separation/Balston
 242 Neck Road
 Haverhill, MA 01835
 T 978 858 0505, F 978 858 0625
www.balstonfilters.com

Filtration & Separation/Finite
 500 Glaspie Street
 Oxford, MI 48371-5132
 T 248 628 6400, F 248 628 1850
www.parker.com/finitefilter

Purification, Dehydration and Filtration Division
 4087 Walden Avenue
 Lancaster, NY 14086
 T 716 685 4040, F 716 685 1010
www.airtek.com

Sales Office
 5900-B Northwoods Parkway
 Charlotte, NC 28269
 T 704 921 9303, F 704 921 1960
www.domnickhunter.com

Engine Filtration & Water Purification

Racor
 3400 Finch Road, PO Box 3208
 Modesto, CA 95353
 T 209 521 7860, F 209 529 3278
www.parker.com/racor

Racor
 850 North West St., PO Box 6030
 Holly Springs, MS 38635
 T 662 252 2656, F 662 274 2118
www.parker.com/racor

Racor
 302 Parker Drive
 Beaufort, SC 29906
 T 843 846 3200, F 843 846 3230
www.parker.com/racor

Racor -- Village Marine Tec.
 2000 West 135th Street
 Gardena, CA 90249
 T 310 516 9911, F 310 538 3048
www.villagemarine.com

Hydraulic Filtration

Hydraulic Filter
 16810 Fulton County Road #2
 Metamora, OH 43540-9714
 T 419 644 4311, F 419 644 6205
www.parker.com/hydraulicfilter

Process Filtration

Process Advanced Filtration
 2340 Eastman Avenue
 Oxnard, CA 93030
 T 805 604 3400, F 805 604 3401
www.parker.com/processfiltration

Europe

Compressed Air Treatment
domnick hunter Industrial
 Dukesway, Team Valley Trading Estate
 Gateshead, Tyne & Wear
 England NE11 0PZ
 T +44 (0) 191 402 9000,
 F +44 (0) 191 482 6296
www.domnickhunter.com

Hiross Zander
Padova Business Unit
 Strada Zona Industriale 4
 35020 S. Angelo di Piove Padova, Italy
 T +39 049 9712 111, F +39 049 9701 911
www.dh-hiross.com

Hiross Zander
Essen Business Unit
 Zander Aufbereitungstechnik GmbH
 Im Teelbruch 118
 D-45219 Essen, Germany
 T +49 2054 9340, F +49 2054 934164
www.zander.de

Parker Gas Separations
 Oude Kerkstraat 4
 P O Box 258
 4870 AG Etten- Leur, Netherlands
 T +31 76 508 5300, F +31 76 508 5333

Engine Filtration & Water Purification

Racor
 Shaw Cross Business Park
 Churwell Vale Dewsbury,
 WF12 7RD England
 T +44 (0) 1924 487000,
 F +44 (0) 1924 487038
www.parker.com/rfde

Racor Research & Development
 Parker Hannifin GmbH & Co KG
 Inselstrasse 3 - 5
 70327 Stuttgart Germany
 T +49 (0)711 7071 290-0,
 F +49 (0)711 7071 290 -70
www.parker.com/racor

Hydraulic Filtration

Hydraulic Filter
 Stieltjesweg 8, 6827 BV
 P.O. Box 5008 6802 EA
 Arnhem, Holland
 T +31 26 3760376, F +31 26 3643620
www.parker.com/eurofilt

Urjala Operation
 Salmentie 260
 31700 Urjala as Finland
 T +358 20 753 2500, F +358 20 753 2501
www.parker.com/fi

Condition Monitoring Center
 Brunel Way Thefford,
 Norfolk IP 24 1HP England
 T +44 1842 763299, F +44 1842 756300
www.parker.com/cmcc

Process Filtration

domnick hunter Process
 Durham Road, Birtley Co. Durham,
 DH3 2SF England
 T +44 (0) 191 410 5121,
 F +44 (0) 191 410 5312
www.domnickhunter.com

Africa

Parker Hannifin Africa Pty Ltd
 Parker Place, 10 Berne Avenue,
 Aeroport Kempton Park,
 1620 South Africa
 T +27 11 9610700, F +27 11 3927213
www.parker.com/eu

Asia Pacific

Australia
 9 Carrington Road, Castle Hill
 NSW 2154, Australia
 T +61 2 9634 777, F +61 2 9899 6184
www.parker.com/australia

China
 280 YunQiao Road
 JinQiao Export Processing Zone
 Shanghai 101206 China
 T +86 21 5031 2525, F +86 21 5834 3714
www.parker.com/china

India
 Plot EL 26, MIDC, TTC Industrial Area
 Mahape, Navi Mumbai 400 709 India
 T +91 22 5613 7081, 82, 83, 84, 85
 F +91 22 2768 6618 6841
www.parker.com/india

Japan
 626, Totsuka-cho, Totsuka-ku
 Yokohama-shi, 244-0003 Japan
 T +81 45 870 1522, F +81 45 864 5305
www.parker.com/japan

Korea
 1-C Block, Industrial Complex of Jangan,
 615-1, Geumui-Ri Jangan-Myeon,
 Hwaseong-City Gyeonggi-Do, Korea
 T +82 31 359 0771, F +82 31 359 0770
www.parker.com/korea

Singapore
 11, Fourth Chin Bee Road
 Singapore 619 702
 T +65 6887 6300, F +65 6261 4929
www.parker.com/singapore

Thailand
 1023 3rd Floor, TPS Building
 Pattanakam Road, SuanLuang,
 Bangkok 10250 Thailand
 T +66 2717 8140, F +66 2717 8148
www.parker.com/thailand

Latin America

Parker Comercio Ltda.
Filtration Division
 Estrada Municipal Joel de Paula
 900 Eugenio de Melo,
 Sao Jose dos Campos
 CEP 12225-390 SP Brazil
 T +55 12 4009 3500, F +55 12 4009 3529
www.parker.com/br

Pan American Division - Miami
 7400 NW 19th Street, Suite A
 Miami, FL 33128
 T 305 470 8800 F 305 470 8808
www.parker.com/panam

© 2010 Parker Hannifin Corporation
 October 2010 / Bulletin LGN2FD09-A

Parker Hannifin Corporation
Filtration and Separation Division
 4711 Hollins Ferry Road, Suite 112
 Baltimore, MD 21227
 Tel: (410) 636-7200
 Fax: (410) 636-7206
www.parker-nni.com

